

DUAL PRE-AMPLIFIER

- Dual pre amplifier for car or home stereo use.
- High voltage gain : $G_{VO}=100\text{dB(Typ.)}$ at $f=1\text{kHz}$.
- Excellent channel separation and high ripple rejection.
 - : $\text{CHsep}=65\text{dB(Typ.)}$
($f=10\text{kHz}$, $R_g=2.2\text{k}\Omega$, $V_{out}=0\text{dBm}$)
 - : $\text{R.R.}=50\text{dB(Typ.)}$
- Low noise : $V_{NI}=1.0\mu\text{V}_{\text{rms}}(\text{Typ.})$ at $R_g=2.2\text{k}\Omega$, $B_w=20\text{Hz} \sim 20\text{kHz}$.
- Wide operating supply voltage range.
 - : $V_{CC}=6 \sim 16\text{V}$ ($T_a=25^\circ\text{C}$)

MAXIMUM RATINGS ($T_a=25^\circ\text{C}$)

CHARACTERISTIC		SYMBOL	RATING	UNIT
Supply Voltage		V_{CC}	16	V
Power Dissipation (Note)	KIA6225P	P_D	600	mW
	KIA6225S		700	
Operating Temperature		T_{opr}	-30 ~ 85	$^\circ\text{C}$
Storage temperature		T_{stg}	-55 ~ 150	$^\circ\text{C}$

Note) Derated above $T_a=25^\circ\text{C}$ in the proportion of $5.6\text{mW}/^\circ\text{C}^2$ for KIA6225S, and of $4.8\text{mW}/^\circ\text{C}$ for KIA6225P.

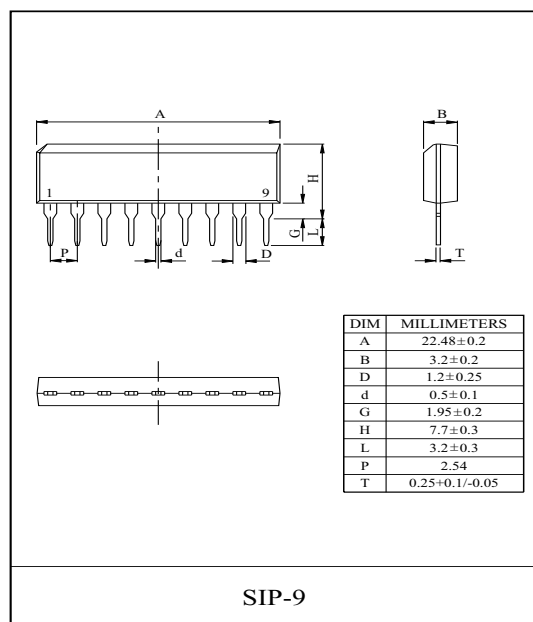
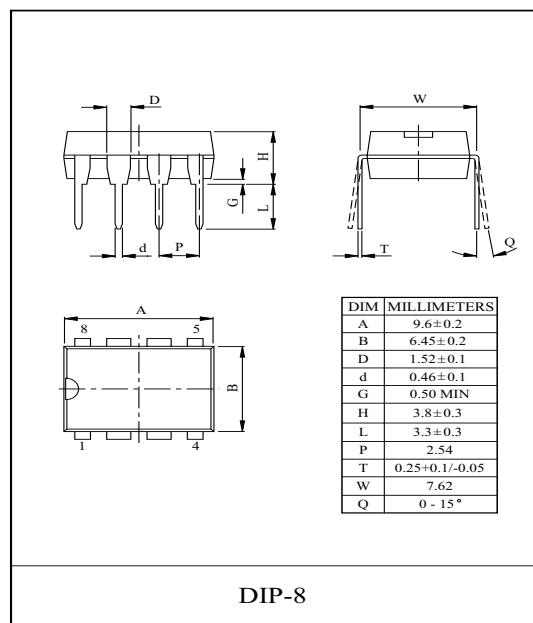

ELECTRICAL CHARACTERISTICS ($T_a=25^\circ\text{C}$)

(Unless otherwise specified, $V_{CC}=6\text{V}$, $f=1\text{kHz}$, $R_g=600\Omega$, $R_L=10\text{k}\Omega$, $T_a=25^\circ\text{C}$)

CHARACTERISTIC	SYMBOL	TEST CIRCUIT	TEST CONDITION	MIN.	TYP.	MAX.	UNIT
Supply Current	I_{CC}	-	$V_{IN}=0$	-	3	6	mA
Voltage Gain	G_{vo}	-	$V_{OUT}=0\text{dBm}$	75	100	-	dB
	G_v	-	$V_{OUT}=0\text{dBm}$	38.5	41.5	44.5	
Maximum Output Voltage	V_{OM}	-	THD=1%	1.0	1.8	-	V_{rms}
Equivalent Input Noise Voltage	V_{NI}	-	$R_g=2.2\text{k}\Omega$, BPF=20Hz ~ 20kHz	-	1.0	1.7	μV_{rms}
Input Resistance	R_{IN}	-	-	50	150	-	$\text{k}\Omega$
Channel Separation	CHsep	-	$f=10\text{kHz}$, $V_{OUT}=0\text{dBm}$	-	65	-	dB
Ripple Rejection	R.R	-	$f=100\text{Hz}$, $R_g=2.2\text{k}\Omega$	-	50	-	dB
Total Harmonic Distortion	THD	-	$V_{OUT}=0\text{dBm}$	-	0.04	0.25	%

KIA6225P/S

TEST CIRCUIT

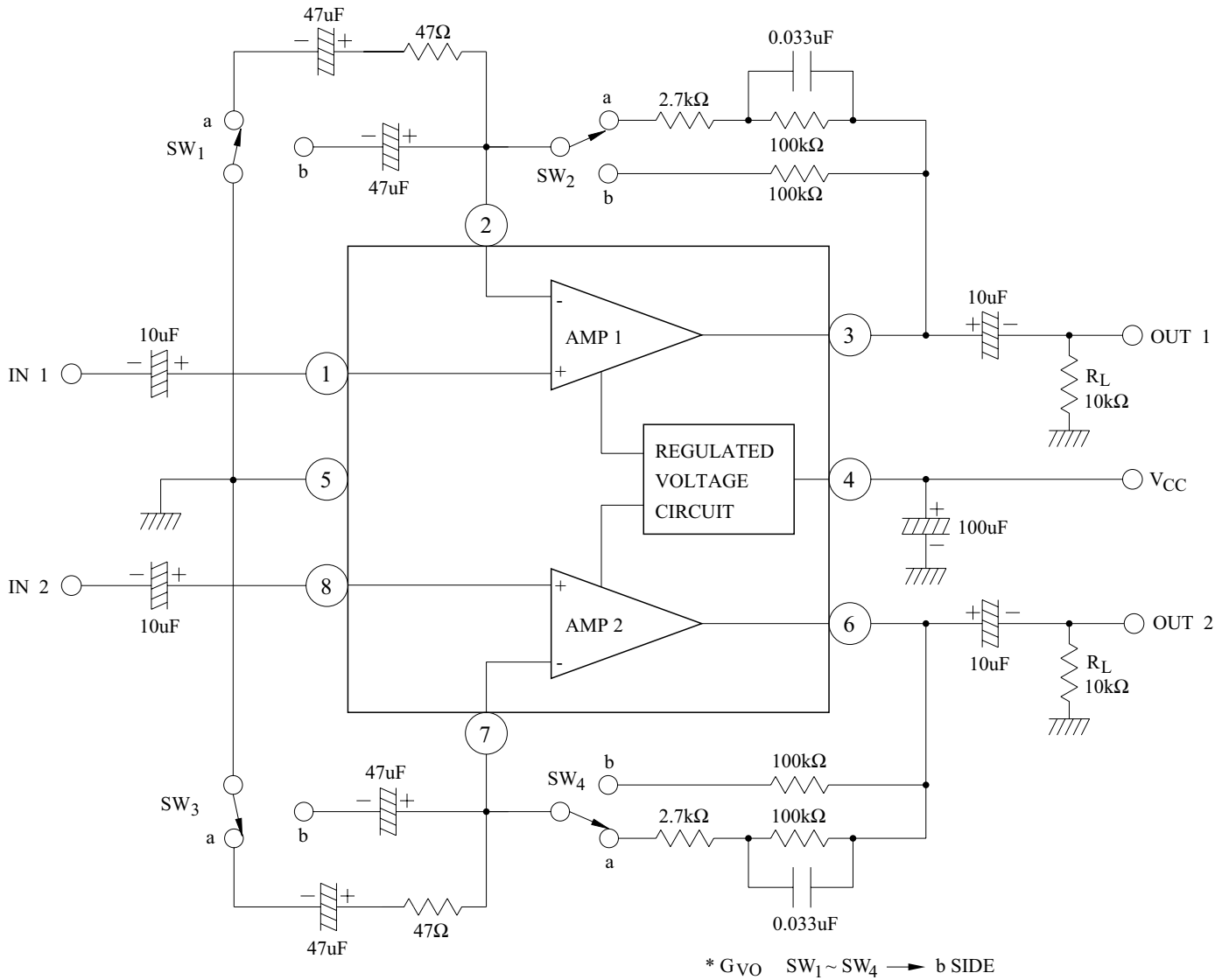

KIA6225P/S

APPLICATION CIRCUIT

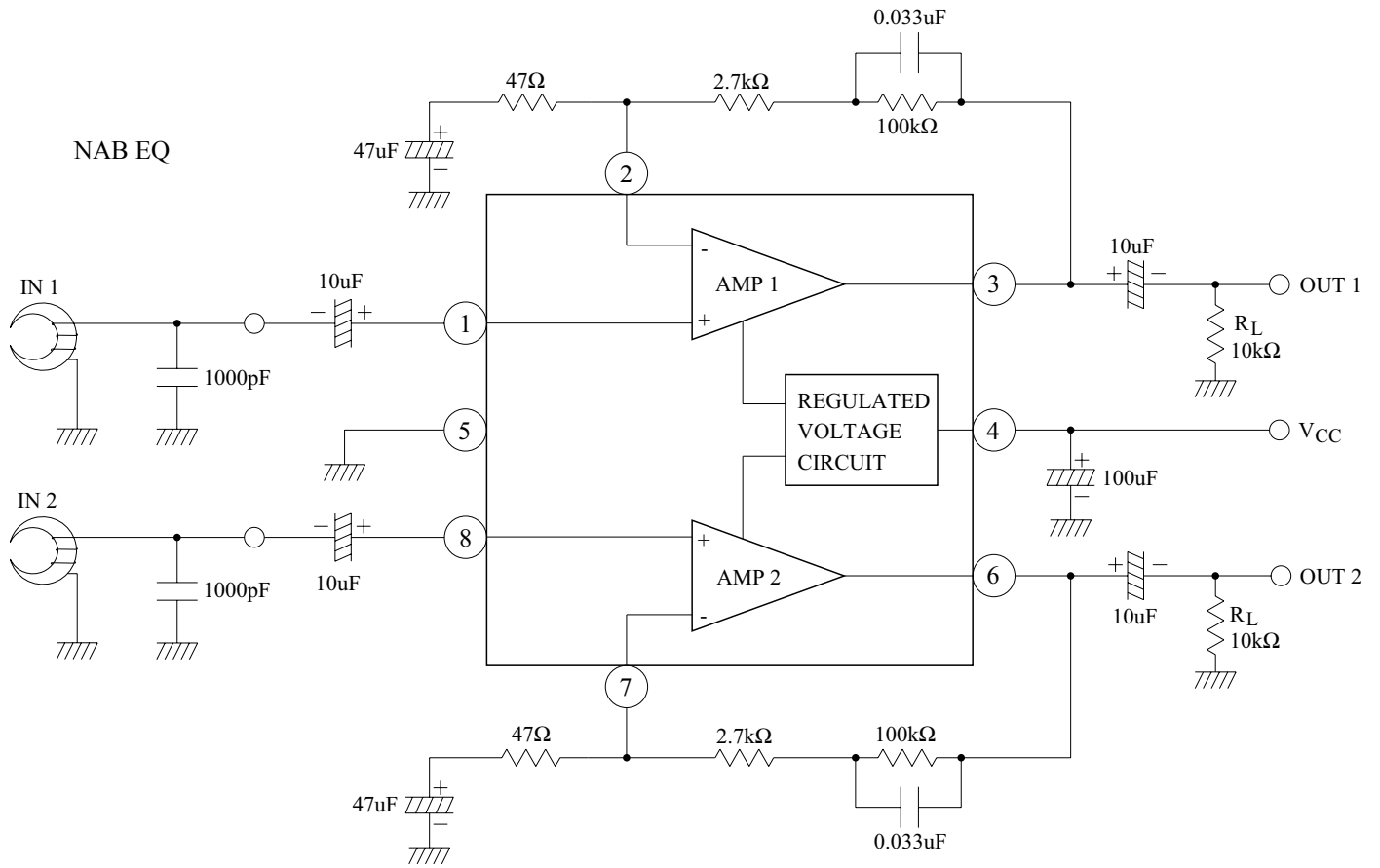

KIA6225P/S

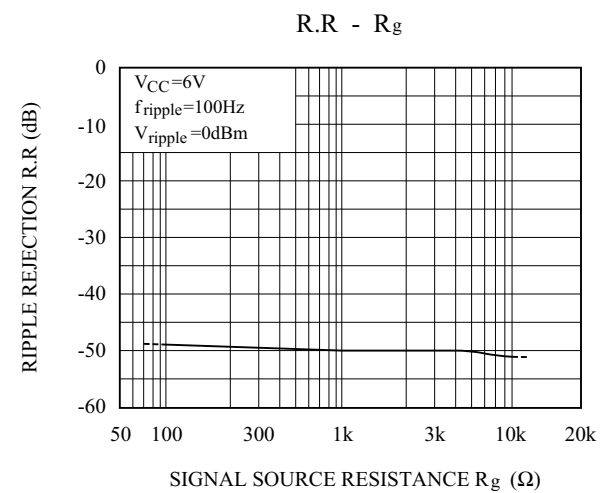
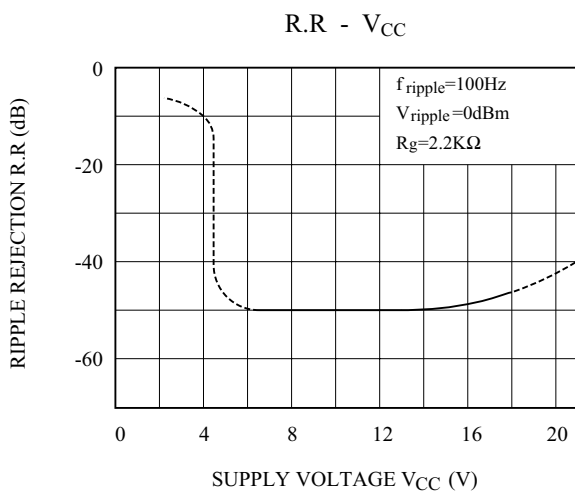
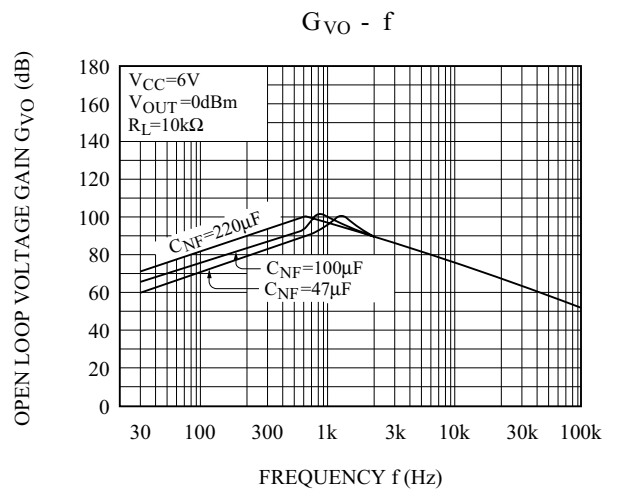
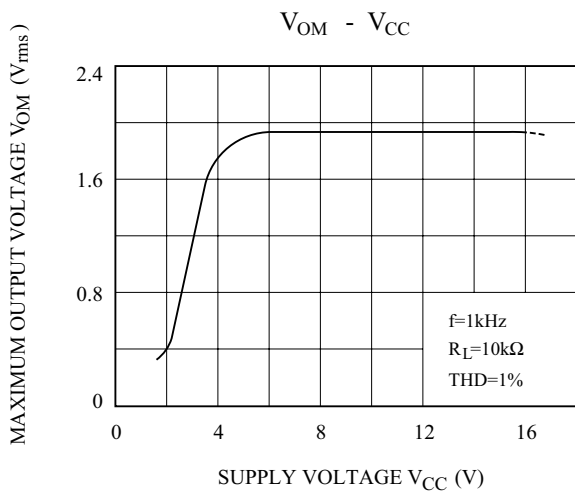
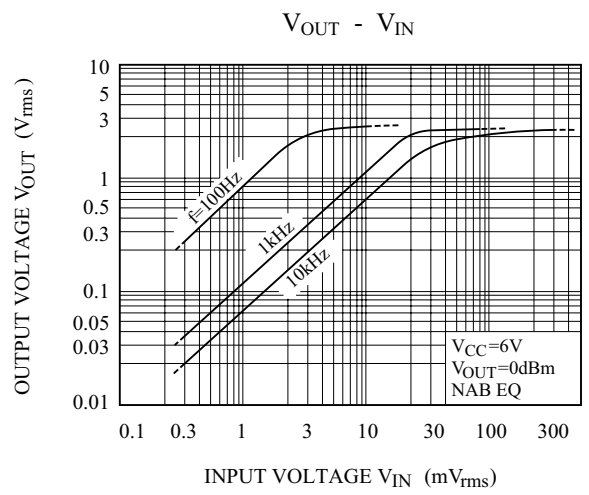
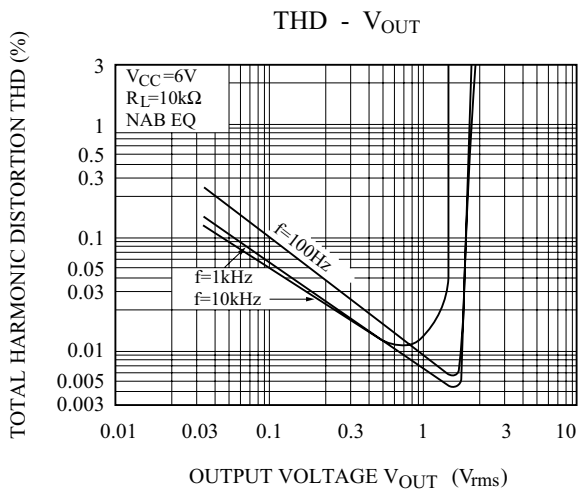

KIA6225P/S

R.R - f

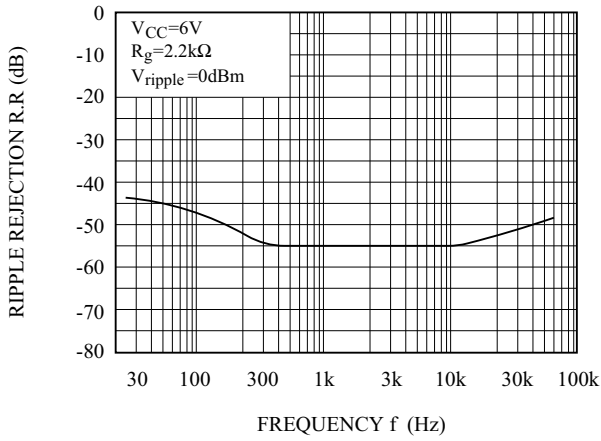

I_{CCQ} - V_{CC}

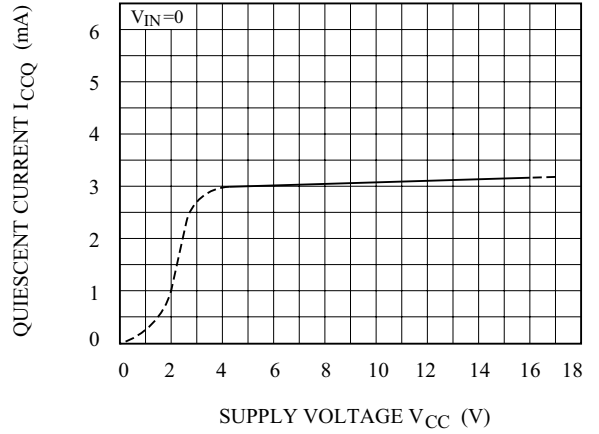

G_V - f

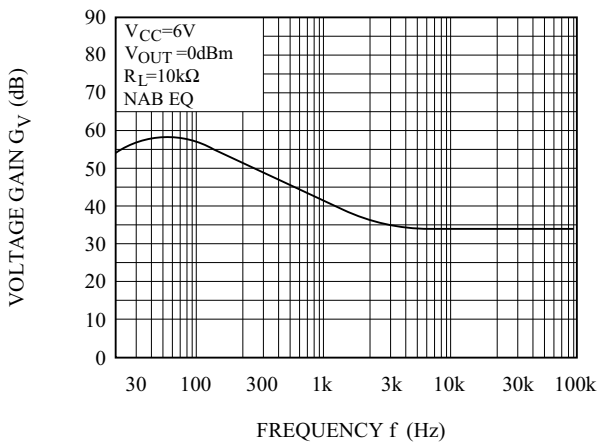

V_{NI} - R_g

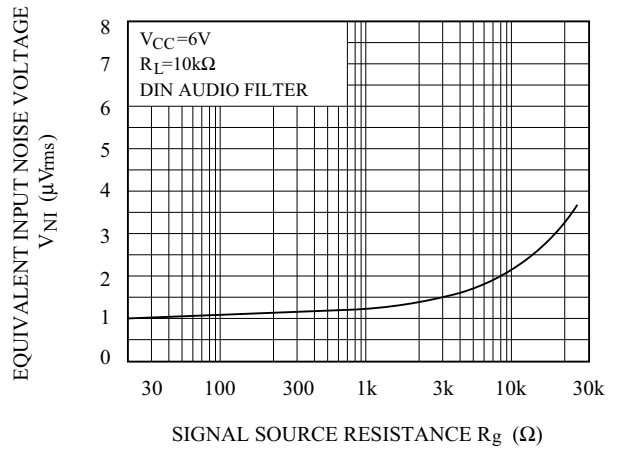

V_{NI} - V_{CC}

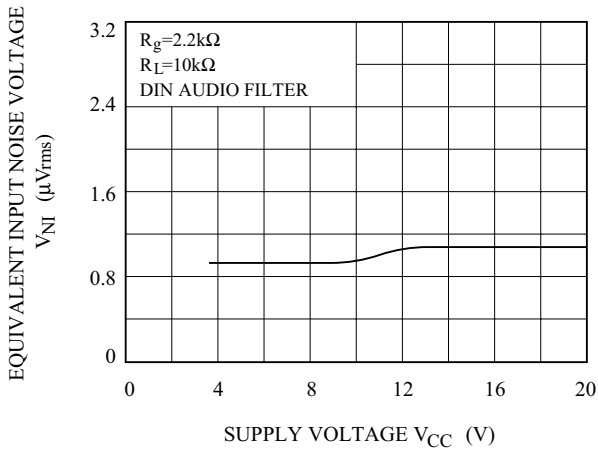

CH_{sep} - f

