

LM3361A Low Voltage/Power Narrow Band FM IF System

General Description

The LM3361A contains a complete narrow band FM demodulation system operable to less than 2V supply voltage. Blocks within the device include an oscillator, mixer, FM IF limiting amplifier, FM demodulator, op amp, scan control, and mute switch. The LM3361A is similar to the MC3361 with the following improvements: the LM3361A has higher voltage swing both at the op amp and audio outputs. It also has lower nominal drain current and a squelch circuit that draws significantly less current than the MC3361. Device pinout functions are identical with some slightly different operating characteristics.

Features

- Functions at low supply voltage (less than 2V)
- Highly sensitive (-3 dB limiting at $2.0 \mu\text{V}$ input typical)
- High audio output (increased 6 dB over MC3361)
- Low drain current (2.8 mA typ., $V_{CC} = 3.6\text{V}$)
- Minimal drain current increase when squelched
- Low external parts count

Block Diagram and Test Circuit

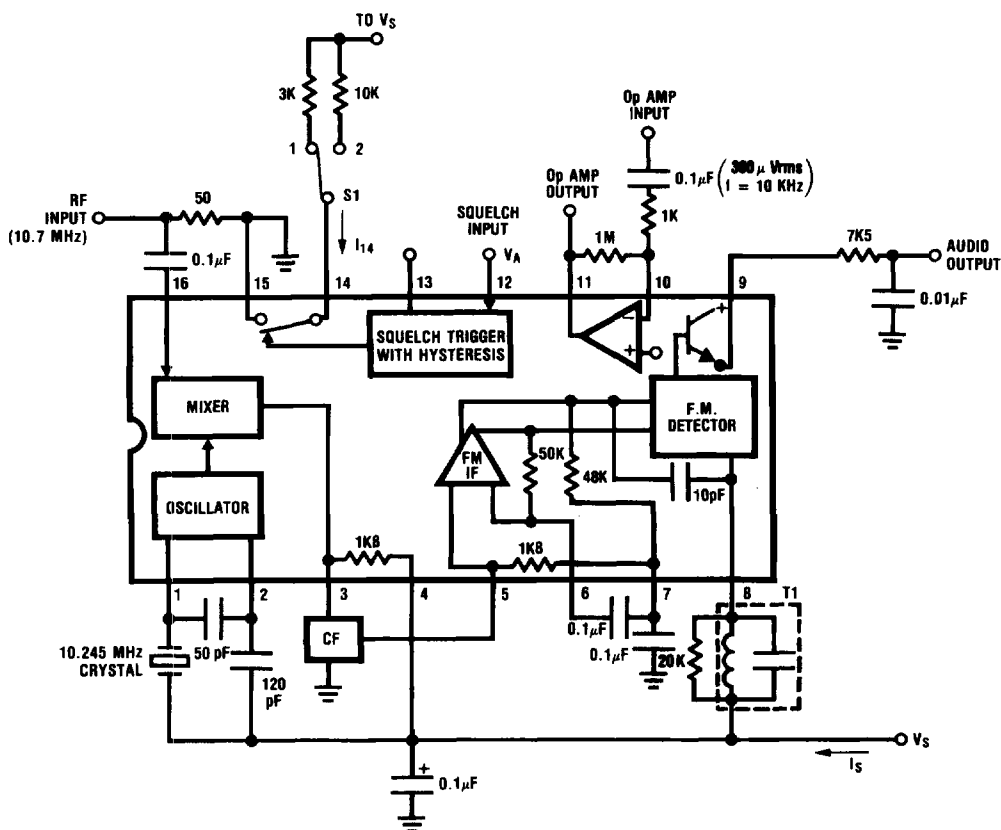

Order Number LM33661AM
or LM33661AN
See NS Package Number
M16A or N16E

T1-TOKO RMC-2A6597HM
CF-MURATA CFU 455E

TL/H/5586-1

Absolute Maximum Ratings

If Military/Aerospace specified devices are required, please contact the National Semiconductor Sales Office/Distributors for availability and specifications.

Package Dissipation (Note 1)	1500 mW
Power Supply Voltage (V_S)	12 V
RF Input Voltage ($V_S > 3.6V$)	1 Vrms
Mute Function (pin 14)	-0.7 to 5 Vp
Operating Ambient Temperature Range	0°C to +70°C
Storage Temperature Range	-55°C to +150°C

Soldering Information

Dual-In-Line Package	
Soldering (10 seconds)	260°C
Small Outline Package	
Vapor Phase (60 seconds)	215°C
Infrared (15 seconds)	220°C

See AN-450 "Surface Mounting Methods and Their Effect on Product Reliability" for other methods of soldering surface mount devices.

Parameters Guaranteed by Electrical Testing

(Test ckt., $T_A = 25^\circ\text{C}$, $V_S = 3.6V$, $f_O = 10.7\text{ MHz}$, $\Delta f = \pm 3\text{ kHz}$, $f_{MOD} = 1\text{ kHz}$, 50 Ω source)

Parameter	Measure	Min	Typ	Max	Units
Supply Voltage Range	V_S	2.0	3.6	9.0	V
Supply Current					
Squelch Off	I_S		2.8	5.0	mA
Squelch On	I_S		3.6	6.0	mA
RF Input for -3 dB Limiting	RF Input		2.0	6.0	μV
Recovered Audio at Audio Output	Audio Output	200	350		mVRMS
Audio Out DC	V_9	1.2	1.5	1.8	V_{DC}
Op Amp Gain	V_{11}/V_{IN}	40	55		dB
Op Amp Output DC	V_{10}	0.4	0.7		V_{DC}
Op Amp Input Bias Current	$(V_{10} - V_{11})/1M\Omega$		20	75	nA
Scan Voltage					
Pin 12 high (2V)	V_{13}		0	0.5	V_{DC}
Pin 12 Low (0V)	V_{13}	3.0	3.4		V_{DC}
Mute Switch Impedance, Pin 12 = 0V Switch S1 from pos.1 to pos.2	$\Delta V_{14}/\Delta I_{14}$		15	30	Ω

Design Parameters Not Tested or Guaranteed

	Typ	
Mixer Conversion Gain (Note 2)	46	V/V
Mixer Input Resistance	3.6	$k\Omega$
Mixer Input Capacitance	2.2	pF
Detector Output Impedance	500	Ω
Squelch Hysteresis	100	mV
Mute Off Impedance (measure pin 14 with pin 12 @ 2V)	10	M Ω
Squelch Threshold	0.65	V_{DC}
Detector Center Frequency Slope	0.15	V/kHz

Note 1. For operation above 25°C ambient temperature, the device must be derated based on 150°C maximum junction temperature and a thermal resistance θ_{JA} of 80°C/W.

Note 2. Mixer gain is supply dependent and effects overall sensitivity accordingly (See Typical Performance Characteristics).

Coils:

Toko America
1250 Feehanville Drive
Mount Prospect, IL 60056
(312) 297-0070

Filters:

Murata
2200 Lake Park Drive
Smyrna, GA 30080
(404) 436-1300

Typical Performance Characteristics (Test Circuits)

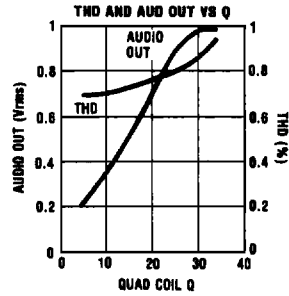
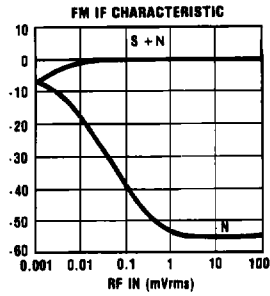
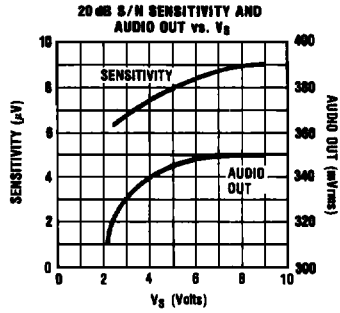
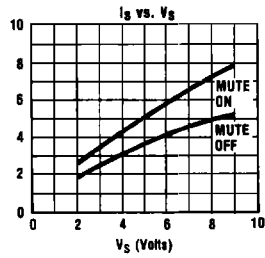

TL/H/5586-2

Internal Schematic

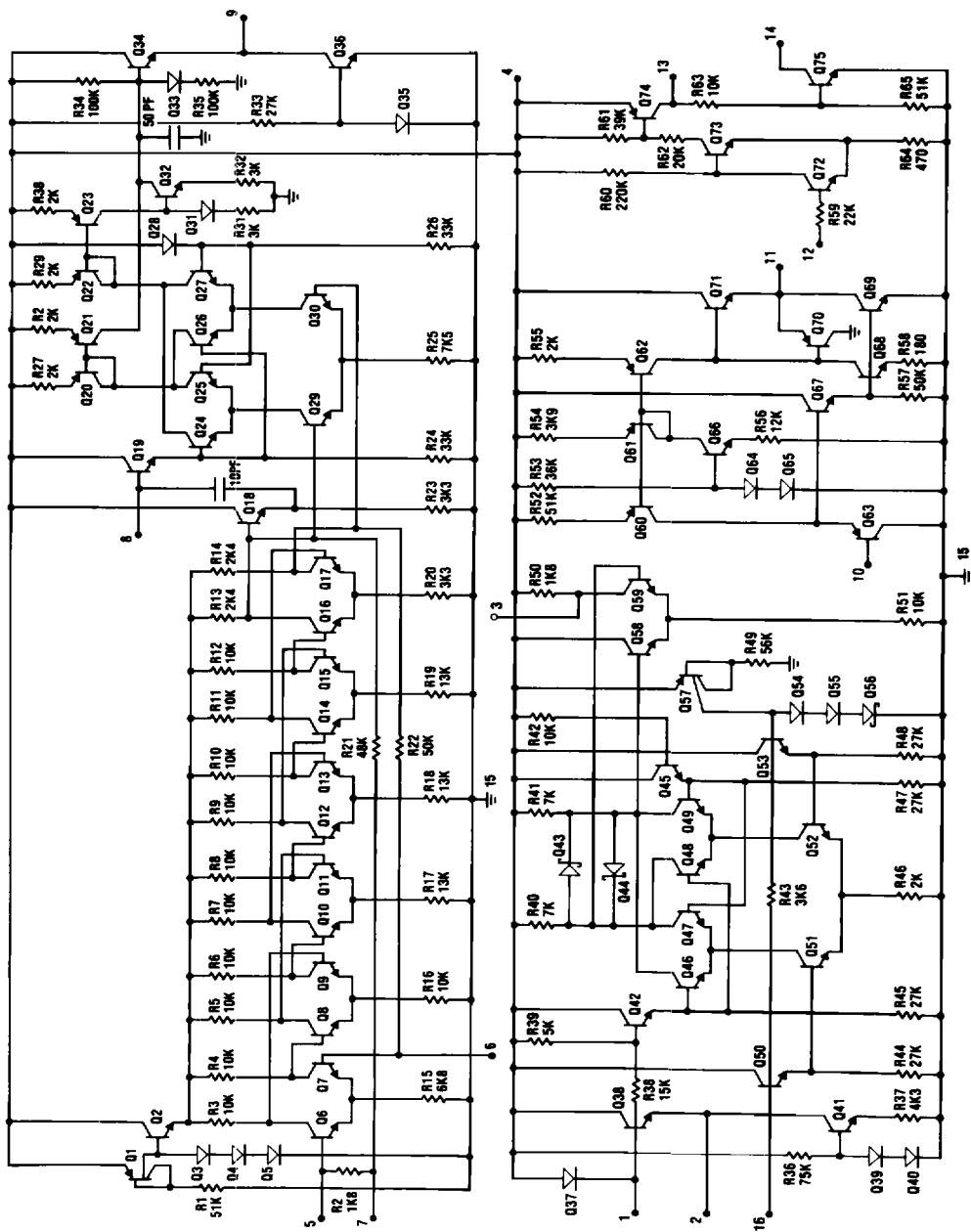

TL/H/5586-3

LM3361A

Applications Information (See Internal Schematic)

OSCILLATOR

The Colpitts type oscillator is internally biased with a regulated current source which assures proper operation over a wide supply range. The collector, base, and emitter terminals are at pins 4, 1, and 2 respectively. The crystal, which is used in the parallel resonant mode, may be replaced with an appropriate inductor if the application does not require the stability of a crystal oscillator. In this case, the resonant frequency will be determined by the inductor in parallel with the series combination of C1 and C2.

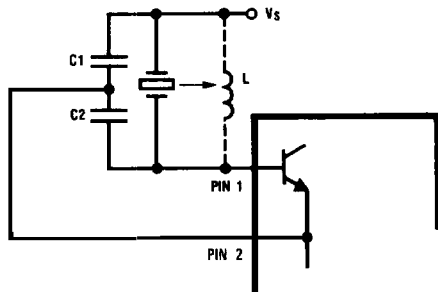

TL/H/5586-4

$$\text{so } C_T = (C_1)(C_2)/(C_1 + C_2)$$

$$\text{and } f_O = .159/\sqrt{L(C_T)}$$

MIXER

The mixer is double balanced to reduce spurious responses. The upper pairs are switched by the oscillator while the RF input is applied to the lower pair (pin 16). R43 sets the mixer input impedance at 3.6 k Ω . The mixer output impedance of 1.8 k Ω will properly match the input impedance of a ceramic filter which is used as a bandpass filter coupling the mixer output to the IF limiting amplifier.

IF LIMITER

The IF amplifier consists of six differential gain stages, with the input impedance set by R2 at 1.8 k Ω to properly terminate the ceramic filter driving the IF. The IF alone (without mixer) has a -3 dB limiting sensitivity of approximately 50 μ V. The system bandwidth is limited to about 5 MHz due to high impedances in the IF which are necessary to meet low power requirements. The IF output is connected to the external quad coil at pin 8 via an internal 10 pF capacitor.

FM DEMOD AUDIO OUT

A conventional quadrature detector is used to demodulate the FM signal. The Q of the quad coil, which is determined by the external resistor placed across it, has multiple effects on the audio output. Increasing the Q increases output level but because of nonlinearities in the tank phase characteris-

tic, also increases distortion (see Typical Performance Characteristics). For proper operation, the voltage swing on pin 8 should be adequate to drive the upper rank of the multiplier into switching (about 100 mVrms). This voltage level is dependent on the internal 10 pF capacitor and the tank R_p voltage divider network. After detection and de-emphasis, the audio output at pin 9 is buffered by an emitter follower.

OP AMP

The op amp inverting input (pin 10) which is internally referenced to 0.7V, receives dc bias from the output at pin 11 through the external feedback network. Because of the low D.C. bias, maximum swing on the op amp output with 10% distortion is 500 mVrms. This can be increased when operating on supplies over 2.3V by adding a resistor from the op amp input to ground which raises the quiescent D.C. at the output allowing more swing (see figure below for selection of added resistor). The op amp is normally utilized as either a bandpass filter to extract a specific frequency from the audio output, such as a ring or dial tone, or as a high pass filter to detect noise due to no input at the mixer. The latter condition will generate a signal at the op amp output, which when applied to pin 12 can mute the external audio amp.

For max swing: $V_{OUT} = (V_S - V_{BE})/2$ (from internal circuit)

$$\text{so } (V_S - V_{BE})/2 = 0.7 \left(1 + \frac{R_2}{R_3} \right)$$

$$\text{therefore } \frac{R_2}{R_3} = \left(\frac{V_S - V_{BE}}{1.4} \right) - 1$$

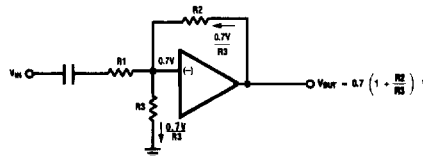

TL/H/5586-5

Increasing OP Amp Swing

SQUELCH TRIGGER CIRCUIT

The squelch trigger circuit is configured such that a low bias on the input (pin 12) will force pin 13 high (200 mV below supply), where it can support at least a 1 mA load, and pin 14 to be a low impedance, typically 15 Ω to ground. Connecting pin 14 to a high impedance ground reference point in the audio path between pin 9 and the audio amp will mute the audio output. Pulling pin 12 above mute threshold (0.65V) will force pin 13 to an impedance of about 60 k Ω to ground and pin 14 will be an open circuit. There is 100 mV of hysteresis at pin 12 which effectively prevents jitter.