

# BIPOLAR ANALOG INTEGRATED CIRCUIT

# $\mu$ PC1230H2

## 25 W AF POWER AMPLIFIER

### DESCRIPTION

The  $\mu$ PC1230H2 is a class B audio power amplifier in a 12-lead single in-line package, specifically designed for car stereo application. Power booster amplifiers are easily designed using this device that provides a high current capability (up to 4.5 A) and that can drive very low impedance loads (down to  $3.2 \Omega$ ) obtaining an output power of more than 20 W.

The  $\mu$ PC1230H2 can be used without output capacitors due to the original protection circuit which protects output power transistors and a speaker at the same time for output DC short circuit to GND.

### FEATURES

- Can be used as OCL connection. (Protection circuit for output DC short circuit to GND)
- Very low output offset voltage :  $V_{\text{offset}} = 150 \text{ mV MAX.}$
- High output power :  $P_O = 25 \text{ W TYP.}$  at  $V_{CC} = 14.4 \text{ V, } R_L = 4 \Omega$   
 $P_O = 20 \text{ W TYP.}$  at  $V_{CC} = 13.2 \text{ V, } R_L = 4 \Omega$
- Very low distortion : T.H.D. = 0.15 % at  $V_{CC} = 13.2 \text{ V, } P_O = 2 \text{ W}$
- Very low number of external components, very simple mounting system with no electrical isolation between the package and the heat sink.
- Low thermal resistance :  $R_{\text{th(j-c)}} = 2.5 \text{ }^\circ\text{C/W}$
- Following protection circuits are provided.
  - (1) Load dump voltage surge protection.
  - (2) Output terminal short circuit protection (short circuit to GND or across the load)
  - (3) Thermal shut down protection
  - (4) Speaker protection (during short circuit for one wire to GND)

### PACKAGE DIMENSIONS (Unit : mm)

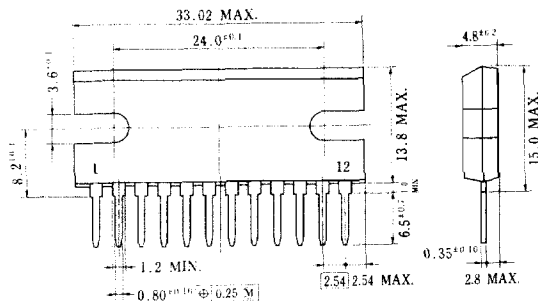

P12HP 254B2

**BLOCK DIAGRAM**

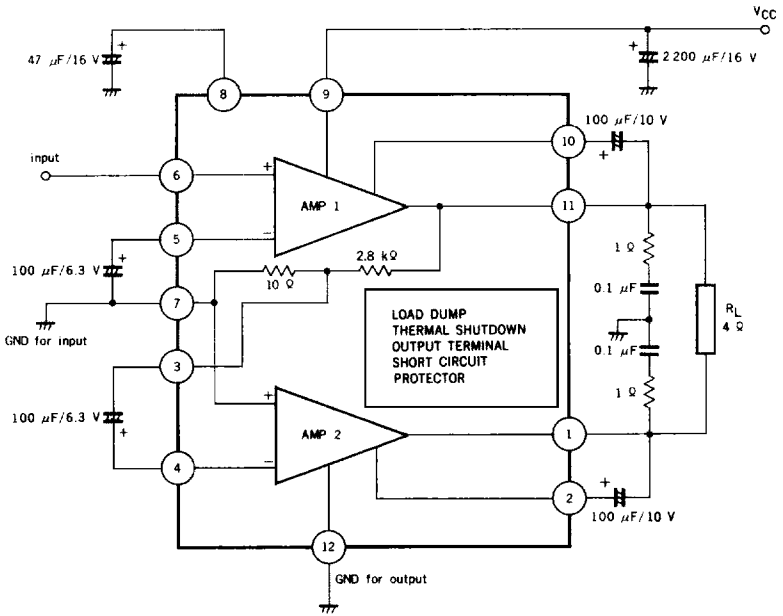

**CONNECTION DIAGRAM**

Pin No.	Function
1	Output 2
2	Bootstrap 2
3	Divided Output
4	Input 2
5	N.F. 1
6	Input 1
7	GND (for input)
8	Filter
9	+VCC
10	Bootstrap 1
11	Output 1
12	GND (for output)

## ABSOLUTE MAXIMUM RATINGS (T<sub>a</sub> = 25 °C)

Supply Voltage (Note)	V <sub>CC surge</sub>	50	V
Supply Voltage (Operational)	V <sub>CC</sub>	18	V
Circuit Current (Peak)	I <sub>CC peak</sub>	4.5	A
Package Dissipation	P <sub>D</sub>	20	W
Operating Temperature	T <sub>opt</sub>	-30 to +75*	°C
Storage Temperature	T <sub>stg</sub>	-55 to +150	°C

\*Using an aluminum heat sink R<sub>th(c-a)</sub> = 4 °C/W  
 Note : Pulse width = 200 ms, t<sub>rise</sub> ≥ 1 ms

## RECOMMENDED OPERATING CONDITIONS (T<sub>a</sub> = 25 °C)

Supply Voltage Range	9.5 to 16	V
Load Impedance	3.2 to 16	Ω

## ELECTRICAL CHARACTERISTICS (T<sub>a</sub> = 25 °C, V<sub>CC</sub> = 13.2 V, R<sub>L</sub> = 4 Ω, f = 1 kHz)

CHARACTERISTIC	SYMBOL	MIN.	TYP.	MAX.	UNIT	TEST CONDITION
Over Voltage Protection	V <sub>CC(MAX.)</sub>	18	19		V	
Quiescent Current	I <sub>CC</sub>	35	90	180	mA	V <sub>in</sub> = 0
Output Offset Voltage	V <sub>offset</sub>		0	±150	mV	V <sub>in</sub> = 0
Output Power	P <sub>O</sub>		25		W	V <sub>CC</sub> = 14.4 V, T.H.D. = 10 %
			16	20	W	V <sub>CC</sub> = 13.2 V, T.H.D. = 10 %
Voltage Gain	A <sub>v</sub>	53	54	56	dB	V <sub>in</sub> = 2.45 mV
Total Harmonic Distortion	T.H.D.		0.15	1.0	%	P <sub>O</sub> = 2 W
Output Noise Level	V <sub>n</sub>		1.2	4	mV	R <sub>G</sub> = 10 kΩ, BW = 20 Hz to 20 kHz
Supply Voltage Rejection Ratio	SVR	34	45		dB	R <sub>G</sub> = 0, f <sub>rip</sub> = 100 Hz, V <sub>rip</sub> = 0.5 V
Input Resistance	R <sub>i</sub>		45		kΩ	
Roll-off Frequency	f <sub>H</sub>		90		kHz	A <sub>v</sub> = -3 dB from 1 kHz Ref. High
	f <sub>L</sub>		15		Hz	A <sub>v</sub> = -3 dB from 1 kHz Ref. Low

## TEST CIRCUIT

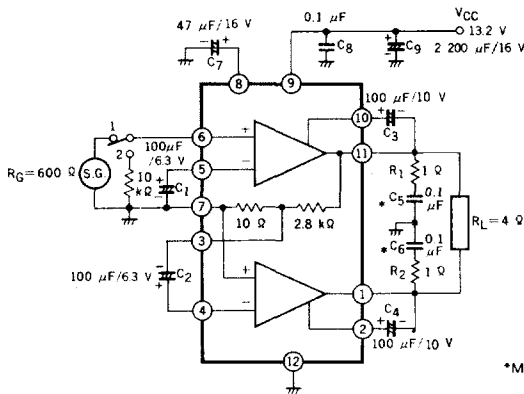

\*Mylar film capacitor

TYPICAL CHARACTERISTICS ( $T_a = 25^\circ\text{C}$ )

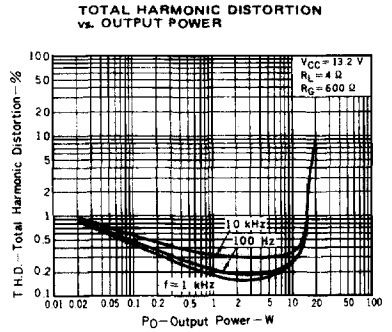
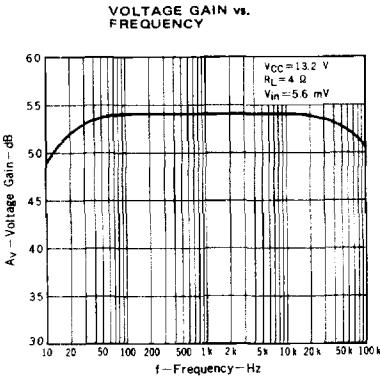
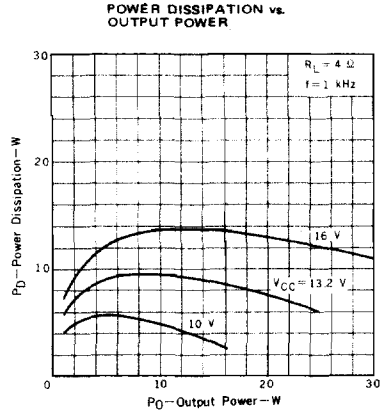
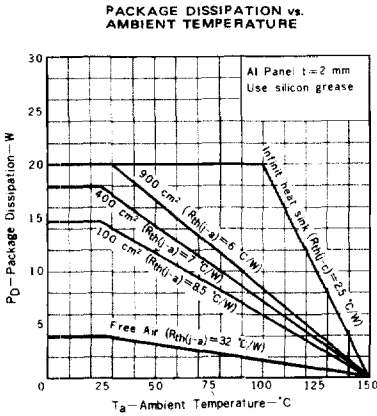

OUTPUT POWER vs. SUPPLY VOLTAGE

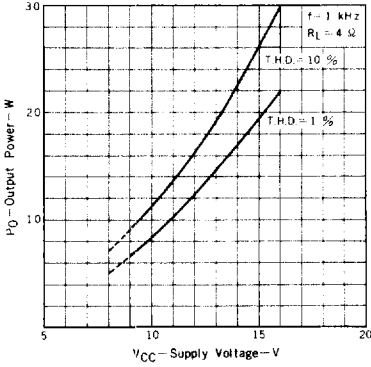

SUPPLY VOLTAGE CHARACTERISTICS

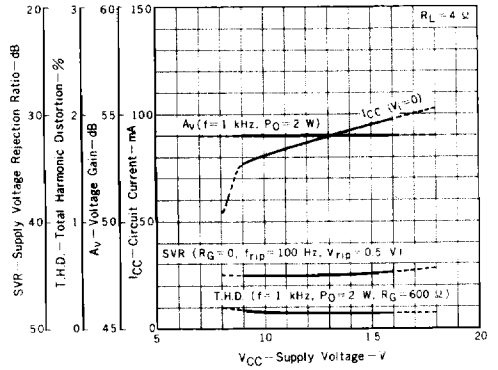

SUPPLY VOLTAGE REJECTION RATIO vs. RIPPLE FREQUENCY

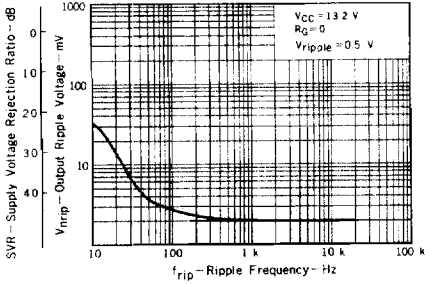

COMPONENTS LAYOUT FOR P.C. ASSEMBLY (Copper side)

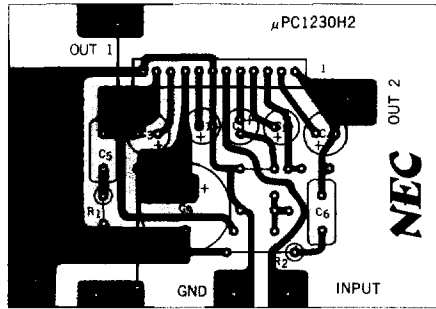

APPLICATION CIRCUIT 1

$A_v \approx 54$  dB

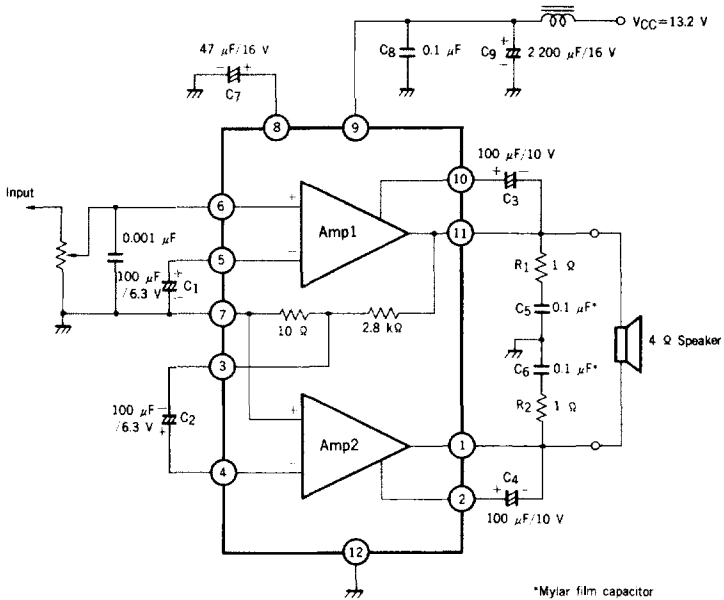

\*Mylar film capacitor

**INSTRUCTION FOR USE**

1. How to attach to the heat sink.
  - Surely use the silicon grease.
  - Keep fastening torque for the screw in the range of 5 to 8 kg-cm.

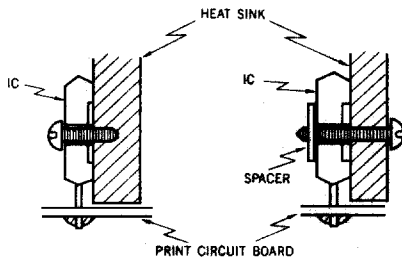

2. When this IC is unstable due to the high impedance of signal source, connect the capacitance (around 1 000 pF) between pin #6 (input) and pin #7 (GND for input).
3. How to decrease voltage gain  $A_v$ .

This IC is designed to use  $A_v$  of 54 dB so that the external components are most reduced.

But  $A_v$  can be set down to 40 dB according to the following application. The modified points are shown by dotted circle and they are additional components. Other external components are as same as application circuit 1.

**(EXAMPLE 1)**

$A_v \approx 40$  dB

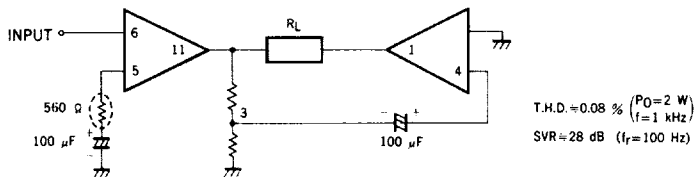

**(EXAMPLE 2)**

$A_v \approx 40$  dB

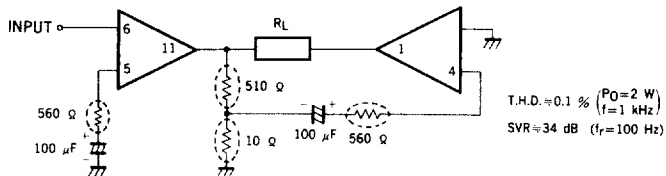

(EXAMPLE 3)

$A_v \approx 40 \text{ dB}$

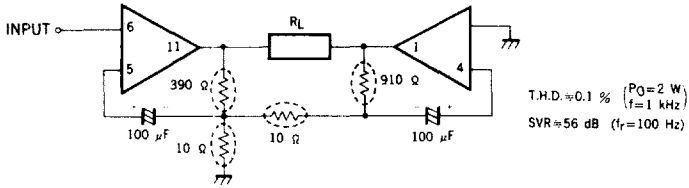

(EXAMPLE 4)

$A_v \approx 40 \text{ dB}$

