

AN5635N, AN5635NS

Chrominance Signal Processing ICs for SECAM System Color TV

Overview

The AN5635N and the AN5635NS are integrated circuits designed for SECAM system color TV chrominance signal processing circuit.

Features

- Incorporates all chrominance signal processing circuits for SECAM system color TV receiver, on a single chip
- By incorporating color matrix circuit, color difference signals are provided
- Built-in color control circuit
- Built-in PAL/SECAM system switch
- Includes color killer function

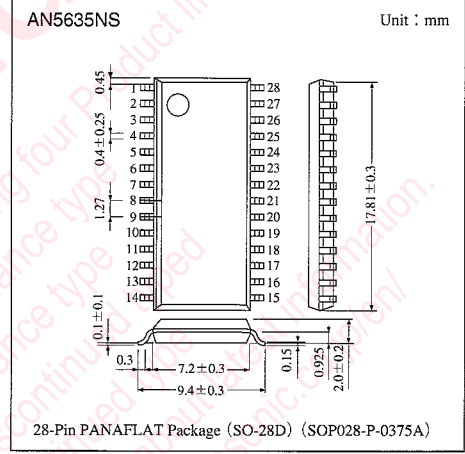
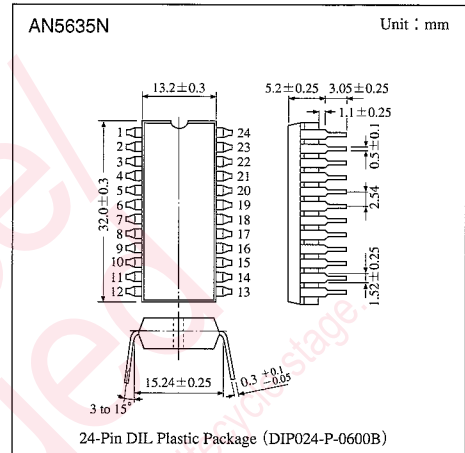

ICs for TV

Block Diagram

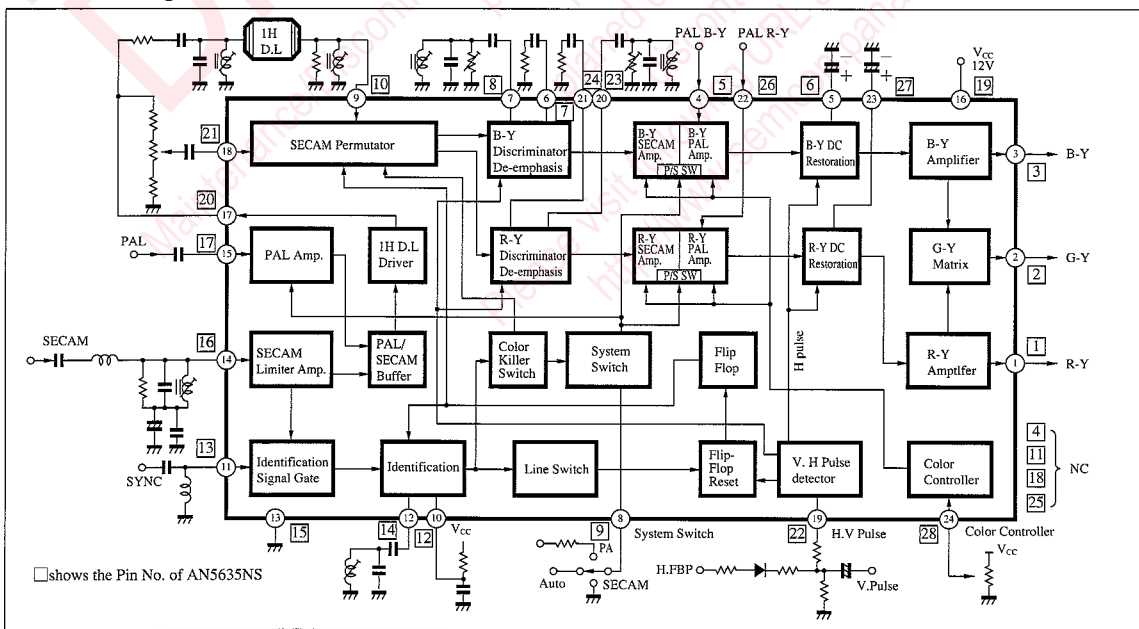

Pin Descriptions () shows the Pin No. of AN5635NS

Pin No.	Pin name	Pin No.	Pin name
1 (1)	R-Y signal output	13(15)	GND
2 (2)	G-Y signal output	14(16)	SECAM signal input
3 (3)	B-Y signal output	15(17)	PAL signal input
4 (5)	PAL B-Y demodulated sig. input	16(19)	V _{CC}
5 (6)	B-Y clamp capacitor	17(20)	Chrominance signal output
6 (7)	B-Y de-emphasis	18(21)	Permutator input (direct)
7 (8)	B-Y discriminator	19(22)	H-V pulse input
8 (9)	System ident. switch	20(23)	R-Y discriminator
9(10)	Permutator input (1H delayed)	21(24)	R-Y de-emphasis
10(12)	System ident. capacitor	22(26)	PAL R-Y demodulated sig. input
11(13)	Gate pulse input	23(27)	R-Y clamp capacitor
12(14)	System ident. discriminator	24(28)	Color control

In case of AN5635NS, No.④, ⑪, ⑱, ⑳, are NC

Absolute Maximum Ratings (T_a = 25°C)

Parameter		Symbol	Rating		Unit
Supply voltage	AN5635N	V _{CC} (V ₁₆₋₁₃)	14.4		V
	AN5635NS	V _{CC} (V ₁₉₋₁₃)	12.0		
Circuit voltage (AN5635N)		V _{8, 11-13}	0	V ₁₆₋₁₃	V
		V _{19, 24-13}	-0.4	V ₁₆₋₁₃	V
		V _{4, 9, 14, 15, 18, 22-13}	0	9	V
Circuit voltage (AN5635NS)		V _{9, 13-15}	0	V ₁₉₋₁₅	V
		V _{22, 28-15}	-0.4	V ₁₉₋₁₅	V
		V _{5, 10, 16, 17, 21, 26-15}	0	9	V
Circuit current		I _{1, 2, 3}	-25	10	mA
Circuit current (AN5635N)		I _{5, 6, 21, 23}	-5	10	mA
		I ₁₀	-10	10	mA
		I ₁₇	-25	0	mA
Circuit current (AN5635NS)		I _{6, 7, 24, 27}	-5	10	mA
		I ₁₂	-10	10	mA
		I ₂₀	-25	0	mA
Power dissipation	AN5635N	P _D	1159		mW
	AN5635NS	P _D	567		
Operating ambient temperature		T _{opr}	-20 to +70		°C
Storage temperature	AN5635N	T _{stg}	-55 to +150		°C
	AN5635NS		-55 to +125		

Electrical Characteristics (Ta=25°C)

Parameter	Symbol	Condition	min	typ	max	Unit	
Total circuit current	I_{tot}	$V_{CC}=12.0V$	49	58	67	mA	
Circuit voltage	AN5635N	$V_{9,14,18-13}$	$V_{CC}=12.0V$	1.7	2.4	3.1	V
	AN5635NS	$V_{10,16,21-15}$					
	AN5635N	V_{15-13}	$V_{CC}=12.0V$	2.7	3.4	4.1	V
	AN5635NS	V_{17-15}					
	AN5635N	V_{17-13}					
AN5635NS	V_{20-15}	$V_{CC}=12.0V, Pin⑩ 3k\Omega GND$	6.6	7.3	8.0	V	
Limiter amp. output voltage 1	e_{lim-1}	Sine wave 4.4MHz 100mV _{P-P} (0dB)	2.1	2.6	3.1	V _{P-P}	
Limiter amp. output voltage 2	e_{lim-2}	Sine wave 4.4MHz 5mV _{P-P} (-26dB)	0.55	1.05	1.55	V _{P-P}	
PAL amp. gain	A_{vPAL}	Sine wave 4.4MHz 300mV _{P-P}	0.75	1.0	1.25	—	
SECAM output R-Y	e_{01R-Y}	Color bar input standard 100mV _{P-P}	4.1	5.2	6.2	V _{P-P}	
SECAM output G-Y	e_{01G-Y}		1.7	2.2	2.6	V _{P-P}	
SECAM output B-Y	e_{01B-Y}		3.7	4.6	5.5	V _{P-P}	
Color control TYP	e_{01TYP}	6V radio for eol B-Y Pin⑭ 12V	0.18	0.28	0.38	times	
Color killer level	e_k	Input at killer operating time (100mV _{P-P}=0dB)}	-46	-39	-32	dB	
System discrimination 1	AN5635N	V_{8-13}	Color-bar input -52dB	1.1	1.3	1.5	V
	AN5635NS	V_{9-15}					
System discrimination 2	AN5635N	V_{8-13}	Color-bar input -26dB	0	0.15	0.3	V
	AN5635NS	V_{9-15}					
System discrimination 3	AN5635N	V_{8-13}	PAL input-burst 100mV _{P-P}	1.1	1.3	1.5	V
	AN5635NS	V_{9-15}					
PAL R-Y/B-Y amp. gain	$A_{vR-Y, B-Y}$	Sine wave 10kHz 500mV _{P-P}	7.2	9.0	10.8	times	
Residual color difference output	e_{04}	Color-bar input standard Pin⑭=1.5V	—	—	60	mV _{P-P}	
Demodulation DC output voltage	$E_{O(DC)}$	Non-input signal	6.7	7.1	7.6	V	
E_O (DC) supply voltage dependency	$\Delta E_{O(DC)}/V_{CC}$	$V_{CC}=12V\pm 20\%$	0.4	0.55	0.7	V/V	
ΔE_{x-y} supply voltage dependency	ΔE_{x-y}	Non-input signal	—	—	± 300	mV	
Output DC differential voltage ΔE_{x-y}	$\Delta E_{x-y}(V_{CC})$	$V_{CC}=12V\pm 20\%$	—	—	± 100	mV	
ΔE_{x-y} color change	$\Delta E_{x-y}(C)$	Color min. to max.	—	—	± 70	mV	
E_{x-y} system SW change	$\Delta E_{x-y}(SW)$	System SW change from PAL to SECAM	—	—	± 50	mV	
System discrimination sampling pulse voltage range	V_{SIG}	Sampling pulse voltage for system discrimination operation	1.5	—	2.4	V	
F. F. gate voltage range	V_{FF}	F. F. reverse pulse voltage	5.5	—	10	V	
Blanking voltage range	V_{BLK}	Blanking operating pulse voltage	1.5	—	4.5	V	

ICs for TV

■ Application Circuit

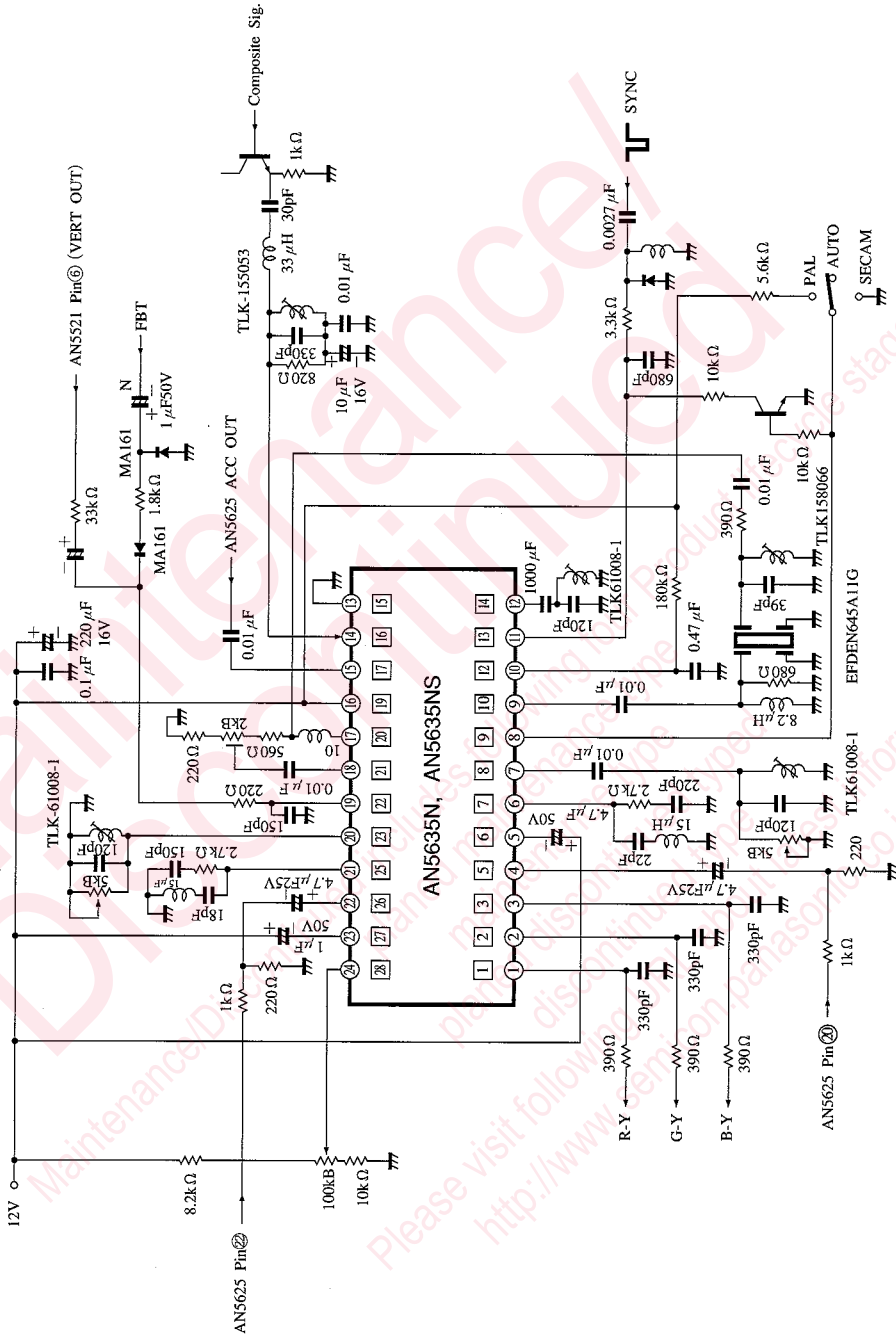

□ shows the Pin No. of AN5635NS (Pin No. 4, 11, 19, 25 are NC)

Request for your special attention and precautions in using the technical information and semiconductors described in this book

- (1) If any of the products or technical information described in this book is to be exported or provided to non-residents, the laws and regulations of the exporting country, especially, those with regard to security export control, must be observed.
- (2) The technical information described in this book is intended only to show the main characteristics and application circuit examples of the products. No license is granted in and to any intellectual property right or other right owned by Panasonic Corporation or any other company. Therefore, no responsibility is assumed by our company as to the infringement upon any such right owned by any other company which may arise as a result of the use of technical information described in this book.
- (3) The products described in this book are intended to be used for standard applications or general electronic equipment (such as office equipment, communications equipment, measuring instruments and household appliances).
Consult our sales staff in advance for information on the following applications:
 - Special applications (such as for airplanes, aerospace, automobiles, traffic control equipment, combustion equipment, life support systems and safety devices) in which exceptional quality and reliability are required, or if the failure or malfunction of the products may directly jeopardize life or harm the human body.
 - Any applications other than the standard applications intended.
- (4) The products and product specifications described in this book are subject to change without notice for modification and/or improvement. At the final stage of your design, purchasing, or use of the products, therefore, ask for the most up-to-date Product Standards in advance to make sure that the latest specifications satisfy your requirements.
- (5) When designing your equipment, comply with the range of absolute maximum rating and the guaranteed operating conditions (operating power supply voltage and operating environment etc.). Especially, please be careful not to exceed the range of absolute maximum rating on the transient state, such as power-on, power-off and mode-switching. Otherwise, we will not be liable for any defect which may arise later in your equipment.
 - Even when the products are used within the guaranteed values, take into the consideration of incidence of break down and failure mode, possible to occur to semiconductor products. Measures on the systems such as redundant design, arresting the spread of fire or preventing glitch are recommended in order to prevent physical injury, fire, social damages, for example, by using the products.
- (6) Comply with the instructions for use in order to prevent breakdown and characteristics change due to external factors (ESD, EOS, thermal stress and mechanical stress) at the time of handling, mounting or at customer's process. When using products for which damp-proof packing is required, satisfy the conditions, such as shelf life and the elapsed time since first opening the packages.
- (7) This book may be not reprinted or reproduced whether wholly or partially, without the prior written permission of our company.