

MINI CUT-OFF SAW

ASSEMBLY & OPERATING INSTRUCTIONS

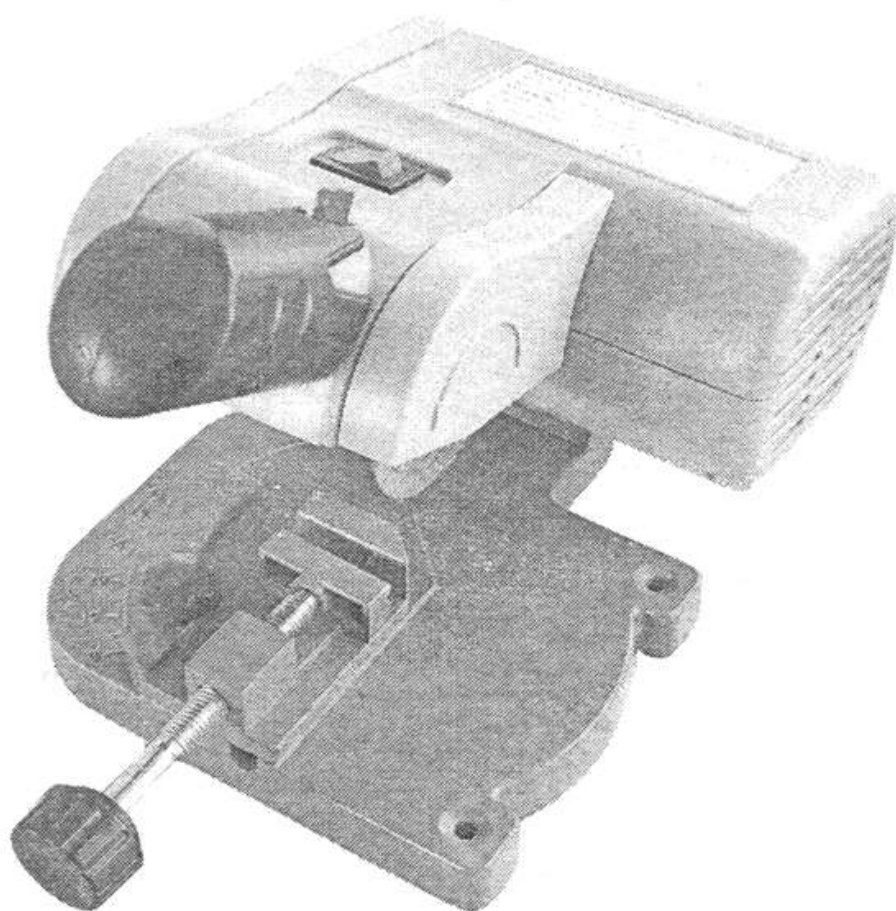

SAVE THE RECEIPT, WARRANTY AND THESE INSTRUCTIONS. It is important that you read the entire manual to become familiar with the unit BEFORE you begin assembly.

Technical Specifications

Tool Name:	Mini Cut-Off Saw								
Arbor:	3/8"								
Blade Diameter:	HSS 2"								
Blade Thickness:	0.020"								
Blade Type:	Multi-Tooth								
Power Source:	<input type="checkbox"/>	110V AC	60Hz	<input type="checkbox"/>	80W	<input type="checkbox"/>	90W	<input type="checkbox"/>	200W
	<input checked="" type="checkbox"/>	220~240 AC	50Hz						
Max. RPM:	7800								
Cutting Depth:	3/4"								
Miter Gauge:	0° -45°								
Base:	5-1/2" L×5" W								
Overall:	9" length×5-1/2" W×6-3/4" H								
Cord:	2 Prong, 71" 18 AWG								
Net Weight:	3LBS.								



IMPORTANT SAFETY INSTRUCTIONS!



READ ALL INSTRUCTIONS BEFORE USING THIS PRODUCT!

Warning: The warnings, cautions and instructions discussed in this instruction manual Cannot cover all possible conditions and situations that may occur. It must be understood by the operator that COMMON SENSE AND CAUTION ARE FACTORS WHICH CANNOT BE BUILT INTO THIS PRODUCT, BUT MUST BE SUPPLIED BY THE OPERATOR.

The Operator

Do not operate the product if under the influence of alcohol or drugs. Read warning labels on prescriptions to determine if your judgment/reflexes might be impaired.

Do not wear loose clothing or jewelry as they can be caught in moving parts.

Protective gloves and non-skid footwear is recommended.

Wear restrictive hair covering to contain long hair.

Use eye and ear protection. Always wear ANSI approved impact safety goggles and a dust mask or respirator when working around metal, wood and chemical dusts and mists.

Wear a full-face shield if your are producing metal or wood filings.

Maintain proper footing and balance at all times.

Keep hands out of the cutting area and away from the blade.

Make certain that the piece being cut is properly supported; do not support the piece being cut by using your hands or leg as a brace.

Avoid carrying the Saw with your fingers on the Handle. Your fingers may touch the Switch and Safety Lever and inadvertently start the Saw.

Work Area

TO AVOID RISK OF PERSONAL INJURY, EQUIPMENT DAMAGE, FIRE AND SHOCK, MAKE SURE YOUR WORK AREA IS:

Free of damp, wet or rainy conditions.

Free of flammable gasses or liquids.

Free of children(never let them handle tools or machinery).

Well-lit.

Clean and uncluttered.

Well-ventilated.

Before Operating

Before operating your Mini-Cut Off Saw check for damaged parts. Before using any tool, any part that appears damaged should be carefully checked to determine that it will operate properly and perform its intended function.

DO NOT exceed the tools maximum capacity.

Never force the tool or attachments to do the work of a larger industrial tool. It is designed to do the job better and more safely at the rate for which it was intended.

Do not try to use inappropriate attachment in an attempt to exceed the tool's capacity.

Make sure all clamps, locks and bolts are tight.

Make certain to turn off and unplug the Saw when changing locations or when doing any maintenance. The tool should always be turned off and unplugged when not in use.

Do not reach over or across running machines.

Assembly

Your Mini Cut-Off Saw will require some assembly. Information on installation is included below for your reference. For assistance with assembly please refer to Figure 1 on page 4 as well as the Assembly diagram on page 7 and the Parts List on page 6.

It is important that you read the entire manual to become familiar with the unit **BEFORE** you use it. Be sure that you have all parts described in the Parts List.

The Mini Cut-Off Saw can be mounted to your table or workbench with four(4)1/8" Bolts(not included).Insert a Bolt through the hole in each corner and tighten it into place with a Nut(not included).The mounting surface must be flat, level and capable of supporting the weight of the Saw combined with the materials to be cut. The Saw can also be mounted by securing the top of the Clamp(part#24)into its slot(See Assembly Diagram) and tightening the bottom of the clamp to the desired work surface.

Installig the Cutting Blade

Step1) With the tool OFF and Unplugged, slide the Blade Guard(part #21)up and off of the Saw.

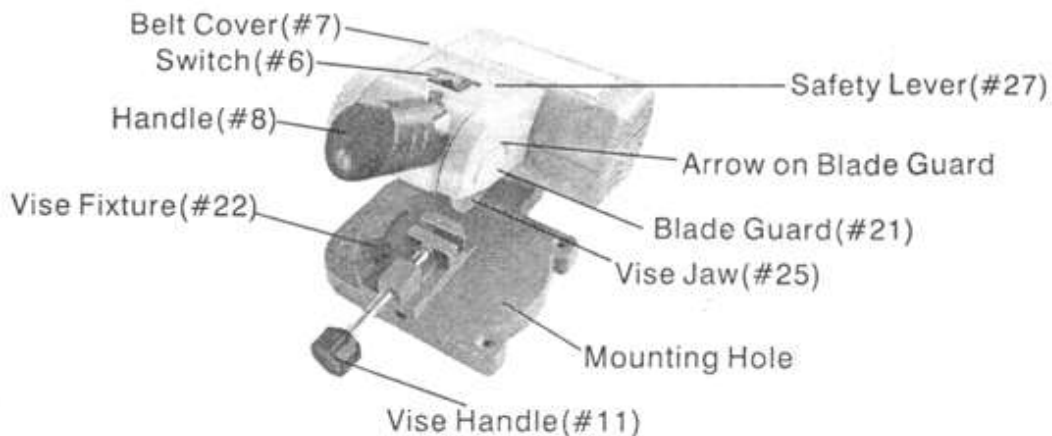

Figure 1-Operating Your Mini Cut-Off Saw

Step2) Insert the HSS Saw Blade (part#18)onto the Arbor(part#16).Slide on the Washer (part#19) and the tighten on the Screw (part#20).Slide the Blade Guard(#21) back on.

Warning : Make certain that the rotational arrow on the Blade Guard (#21) and on the HSS Saw Blade (#18)are facing in the same direction.

Replacing the Timing Belt

Step 1) Slide the Belt Cover (part#7) up to remove it from the Saw. This will expose the Timing Belt (part #5) and the Driving Pulleys(part #12 and part #4).

Step 2) Slide the one end of the Timing Belt (#5) over the Driving Pulley (part#4).Once this side is in place, side the other end of the Timing Belt(#5) over the Driving Pulley(#12).

Step 3) Make certain that the Timing Belt (part #5)is centered on both Driving Pulleys(#12). Replace the Belt Cover (part #7)by sliding it back down into place.

Operation

When operating your Mini Cut-Off Saw, it will be helpful to refer to Figure 1 as well as to the Parts List and Assembly Diagram located on pages 6 and 7.

Setting the Viee

Step 1) The Miter Gauge on the Vise (part #9) can Oe set from 0~-45~.Loosen the Vise Fixture (part #22) and slide the Gauge to the desired angle. Tighten the Vise Fixture into place.

Step 2) The Vise Jaw (Part #25) can be adjusted for the work piece with the Vise Handle(part #11). Turning the Vise Handle(#11) clockwise will tighten the Vise Jaw(s) onto the workpiece. Turning the Vise Handle counterclockwise will loosen the Vise Jaw.

Cutting

- Step 1) Place the material to be cut in the Vise (part #9) as described above.
- Step 2) The Mini Cut-Off Saw has a Safety Lever (part #27) which must be released to lower the Blade. Pushing down on the Safety Lever (part #27) will release the Safety Lever, allowing you to push down on the Handle (part #8) to begin cutting.
- Step 3) Turn the Saw ' ON ' by pressing down on the red Switch (part #6) on the side marked with —. To turn the Saw "Off" ,press down on the end of the Switch (#6) marked O.
- Step 4) With the Saw at full speed, move it slowly forward to complete the cut.
- Step 5) When the cut is complete, pull up on the Handle (part #8). The Safety Lever (#27) will engage. Turn the Saw "Off" .

Maintenance

CLEANING: Remove all sawdust that has accumulated around the Blade Guard (#21), the Motor (#1) and the Motor Housing (#36).

Regularly clean the work surface with a vacuum cleaner or a dry brush. At the end of every work session remove sawdust from the motor vents. Prevent wood, dust and debris from accumulating in the working area.

Keep the Saw Blade (#18) clean and sharp. A sharp blade will minimize stalling and kickback.

STORAGE: Child-proof the machine and work area.

IF THERE IS ANY QUESTION ABOUT A CONDITION BEING SAFE OR UNSAFE, DO NOT OPERATE THE TOOL.

PLEASE READ THE FOLLOWING CAREFULLY

THE MANUFACTURER AND/OR DISTRIBUTOR HAS PROVIDED THE PARTS DIAGRAM IN THIS MANUAL AS A REFERENCE TOOL ONLY. NEITHER THE MANUFACTURER NOR DISTRIBUTOR MAKES ANY REPRESENTATION OR WARRANTY OF ANY KIND TO THE BUYER THAT HE OR SHE IS QUALIFIED TO MAKE ANY REPAIRS TO THE PRODUCT OR THAT HE OR SHE IS QUALIFIED TO REPLACE ANY PARTS OF THE PRODUCT. IN FACT, THE MANUFACTURER AND/OR DISTRIBUTOR EXPRESSLY STATES THAT ALL REPAIRS AND PARTS REPLACEMENTS SHOULD BE UNDERTAKEN BY CERTIFIED AND LICENSED TECHNICIANS AND NOT BY THE BUYER. THE BUYER ASSUMES ALL RISK AND LIABILITY ARISING OUT OF HIS OR HER REPAIRS TO THE ORIGINAL PRODUCT OR REPLACEMENT PARTS THERETO, OR ARISING OUT OF HIS OR HER INSTALLATION OF REPLACEMENT PARTS THERETO.

Unpacking

UNPACK AND CHECK CONTENTS

When unpacking your Mini-Cutoff Saw, check to make sure the following parts are included.

Parts List-#

Part #	Description	Quantity	Part #	Description	Quantity
1	Motor	1	22	Vise Fixture	1
2	Washer	4	23	Nut	1
3	Locking Nut	2	24	Clamp	1
4	Driving Pulley	1	25	Vise Jaw	1
5	Timing Belt	1	26	Spacer	1
6	Switch	1	27	Safety Lever	1
7	Belt Cover	1	28	Spring	1
8	Handle	1	29	Pin	1
9	Vise	1	30	Ring	2
10	Base	1	31	Motor Housing A	1
11	Vise Handle	1	32	Cord Clamp	1
12	Driving Pulley	1	33	Screw	2
13	Screw	4	34	Cord Cover	1
14	Berring	2	35	Cord with Plug	1
15	Spindlr	1	36	Motor Housing B	1
16	Arbor	1	37	Screw	6
			38	Vibration Absorber	1
18	HSS Saw Blade	1	39	Busing	1
19	Washer	1	40	Screw	1
20	Screw	1	41	Spring	1
21	Blade Guard	1	42	Hex Wrench	1

Assembly Diagram

