



常州市丽控机电有限公司

<http://www.likomotor.com>

电话: 0519-81583860

**28BYGH1.8° 两相步进电机**

1.8°Size 28mm(11H) High Torque Hybrid Stepping Motor

**技术参数 Technique parameter**



项目 Item	规格 Specifications
步距角精度 Step Angle Accuracy	±5%(full step,no load)
电阻精度 Resistance Accuracy	±10%
电感精度 Inductance Accuracy	±20%
温升 Temperature Rise	80°C Max.(rated current,2 phase on)
环境温度 Ambient Temperature	-10°C-+50°C
绝缘电阻 Insulation Resistance	100MΩMin.500 VDC
介电强度 Dielectric Strength	500VAC for one minute
转轴径向跳动 Shaft Radial Play	0.06Max.(450 g-load)
转轴轴向跳动 Shaft Axial Play	0.08Max.(450 g-load)
绝缘等级 Insulation Class	Class B 130°

**技术规格 Technique Specification**

型号 Model No.		电压 Rated Voltage	电流 Current /Phase	电阻 Resistance /Phase	电感 Inductance /Phase	最大静力矩 Holding Torque		引线 #of leads	转子转动惯量 Rotor Inertia	重量 Weight	机身长 Length
单出轴 Single Shaft	双出轴 Double Shaft	V	A	Ω	mH	Oz-in	kg-cm		g-cm <sup>2</sup>	Kg	mm
28BYGH32-0956A	28BYGH32-0956B	2.66	0.95	2.8	1	6	0.43	6	9	0.11	32
28BYGH32-0674A	28BYGH32-0674B	3.8	0.67	5.6	4.2	8.3	0.6	4	9	0.11	32
28BYGH45-0956A	28BYGH45-0956B	3.2	0.95	3.4	1.2	10.4	0.75	6	12	0.14	45
28BYGH45-0674A	28BYGH45-0674B	4.6	0.67	6.8	4.9	13.2	0.95	4	12	0.14	45
28BYGH51-0956A	28BYGH51-0956B	4.4	0.95	4.6	1.4	12.5	0.9	6	18	0.2	51
28BYGH51-0674A	28BYGH51-0674B	6.2	0.67	9.2	5.7	16.7	1.2	4	18	0.2	51

**械尺寸 Dimension**

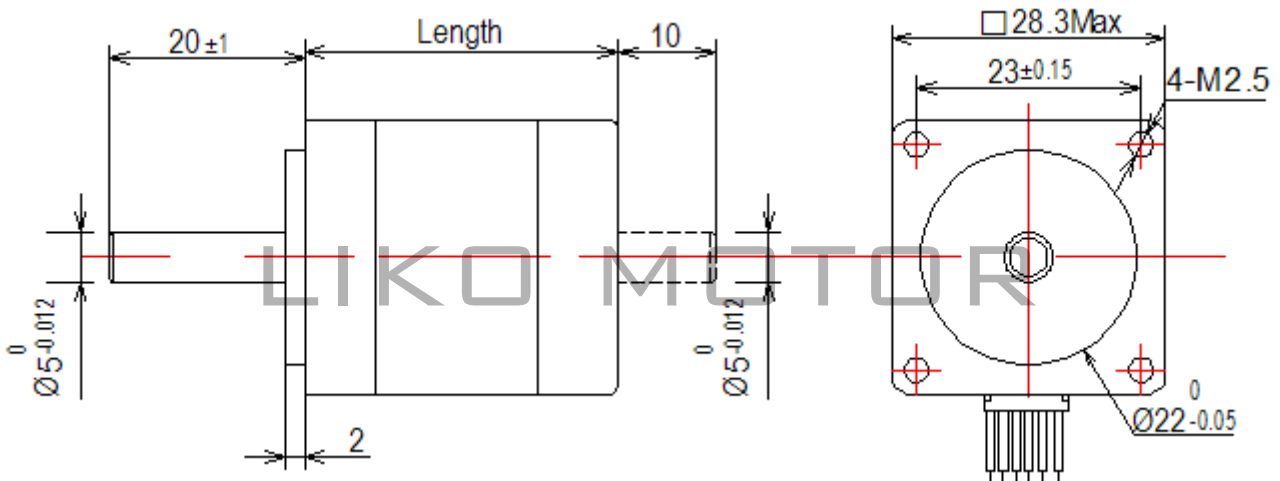

**28BYGH1.8° 两相步进电机 (11H 系列)**  
 1.8° Size 28mm (11H) High Torque Hybrid Stepping Motor



**接线图 Wiring Diagram**

4LEADES

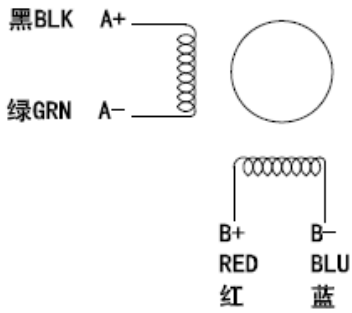

6LEADES

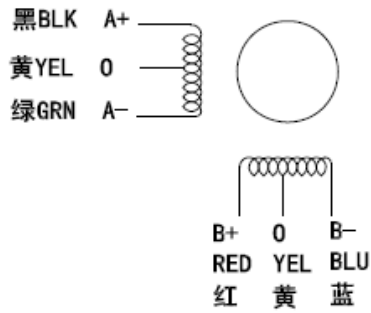

8LEADES

