

User Manual for

WisLink-Cellular

NB-IoT/CAT-M/CAT 1/CAT 4 with VoLTE Supported
Raspberry Pi HAT Edition

RAK2013

Version V1.1 | November 2018

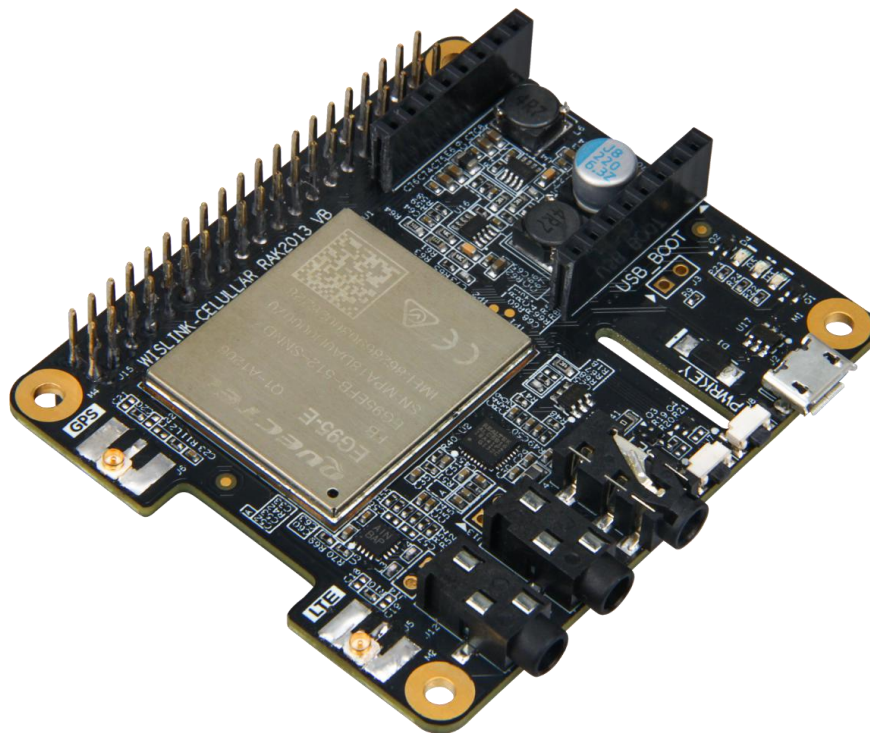

www.RAKwireless.com

Visit our website for more documents.

23 PAGES



Table of Content

1 Overview.....	4
1.1 Introduction.....	4
1.2 Main Features.....	4
1.3 Package Contents.....	5
2 WisLink Cellular RAK2013.....	6
2.1 Overview.....	6
2.2 Functional Diagram.....	8
2.3 Interfaces.....	8
2.4 Frequency Bands and Data Rate.....	9
2.4.1 BG96 Module.....	9
2.4.2 EG91 Module.....	9
2.4.3 EG95 Module.....	9
2.5 Board Pin Out.....	10
2.5.1 J3 – Boot Jumper.....	10
2.5.2 J15 – Raspberry Connector.....	10
2.5.3 J16 and J17 – MikroBus Interface.....	11
2.6 Micro-B USB Interface.....	12
2.7 LEDs.....	12
2.8 RESET Push Button.....	13
2.9 PWRKEY Push Button.....	13
2.10 Antenna RF interface.....	13
2.11 Power Requirements.....	13
2.12 Environmental Requirements.....	13
2.13 Mechanical Dimensions.....	14
3 LTE Antenna.....	15
3.1 Overview.....	15
3.2 Antenna Dimension.....	15
3.3 Antenna Parameter.....	16
4 GPS Antenna.....	17
4.1 Overview.....	17
4.2 GPS Antenna Dimensions.....	17
4.3 GPS Environmental Requirements.....	17
4.4 GPS Antenna Parameter.....	18
5 Schematics.....	19
6 Contact Information.....	22
7 Revision History.....	23
8 Document Summary.....	23

List of Tables

Table 1 BG96 Frequency Bands.....	9
Table 2 EG91 Frequency Bands.....	9
Table 3 EG95 Frequency Bands.....	9
Table 4 Pin Definitions.....	11
Table 5 Micro-B USB Pins.....	12
Table 6 LEDs and their functions.....	12
Table 7 Power Requirements.....	13
Table 8 Environment Requirements.....	14
Table 9 LTE Antenna Parameter.....	16
Table 10 GPS Environmental Requirements.....	17
Table 11 GPS Antenna Parameter.....	18
Table 12 Amplifier Specifications.....	18
Table 13 Environmental Test Performance.....	18

List of Figures

Figure 1 Package Contents.....	5
Figure 2 RAK2013 Overview.....	6
Figure 3 RAK2013 Overview.....	7
Figure 4 RAK2013 Dimension.....	7
Figure 5 RAK2013 Functional Diagram.....	8
Figure 6 RAK2013 Raspberry Connector.....	10
Figure 7 MikroBus Interface.....	11
Figure 8 Mechanical Dimensions.....	15
Figure 9 LTE Antenna.....	15
Figure 10 LTE Antenna Dimension.....	16
Figure 11 GPS Antenna.....	17
Figure 12 GPS Antenna Dimensions.....	17
Figure 13 Power and MikroBus Interface.....	19
Figure 14 BG96 and Raspberry Interface.....	20
Figure 15 Audio codec and Amplifier.....	21

1 Overview

1.1 Introduction

The RAK2013 is a Raspberry Pi 3B+ edition cellular communications module that supports Low-Power Wide-Area (LPWA) technology for networking Internet-of-Things (IoT) devices. It can support optional BG96 / EG91 / EG95 for 4G/LTE, NB-IoT, CAT-M, CAT1 or CAT 4 cellular protocol. The RAK2013 integrates audio codec and audio amplifier on it, with carrier operator's network, it also supports Voice-over-LTE (VoLTE) for high definition (HD) and uninterrupted voice calls. For easy use, there are earphone connector, MIC connector and speaker connector with audio amplifier.

It also supports connector to extend sensor board. The sensor board connector follows MikroBus standard, MikroBus has many kinds of sensor board, such as temperature, humidity, 3 axis sensor, light sensor etc. It is easy to get sensor data through MikroBus interface and can transmit the sensor data through cellular network to your server.

The RAK2013 can connect to RAK2245 Pi Hat board directly, which is RAK's LoRa concentrator module following Raspberry Pi 3B+ edition. It is easy to make a LoRaWAN gateway by plugging them to a Raspberry Pi board, it can transmit LoRa data to cloud server by cellular network.

1.2 Main Features

- Compatible with Raspberry Pi 3B+ edition specification.
- Support optional cellular module(Quectel BG96 or EG91 or EG95) for NB-IOT / CAT-M / CAT1 LTE / CAT4 LTE.
- Supports Voice over CAT-M or VoLTE.
- Supports Nano SIM card or eSIM card.
- Integrates audio codec and audio amplifier.
- Integrates MikroBus interface to support sensor extended board.
- Can be added to another Pi HAT to support LoRa concentrator.
- Supports USB connector for higher data rate.
- Supports GPS function(only for BG96 module) .
- SMA/IPEX antenna optional for LTE and GPS.
- Supports I2C, GPIOs, UART and ADC interfaces for Raspberry board.
- Supports EEPROM to configure IOs automatically.



1.3 Package Contents

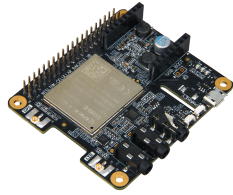

RAK2013 board
(1x)



LTE Antenna
(1x/2x)



GPS Antenna
(1x only for BG96)



Micro USB cable
(1x)

Figure 1 | Package Contents

Note: All the pictures are just for reference, if any discrepancy, please adhere to the actual product instead.

2 WisLink Cellular RAK2013

2.1 Overview

Here is the top view and external interfaces of RAK2013 cellular add-on board.

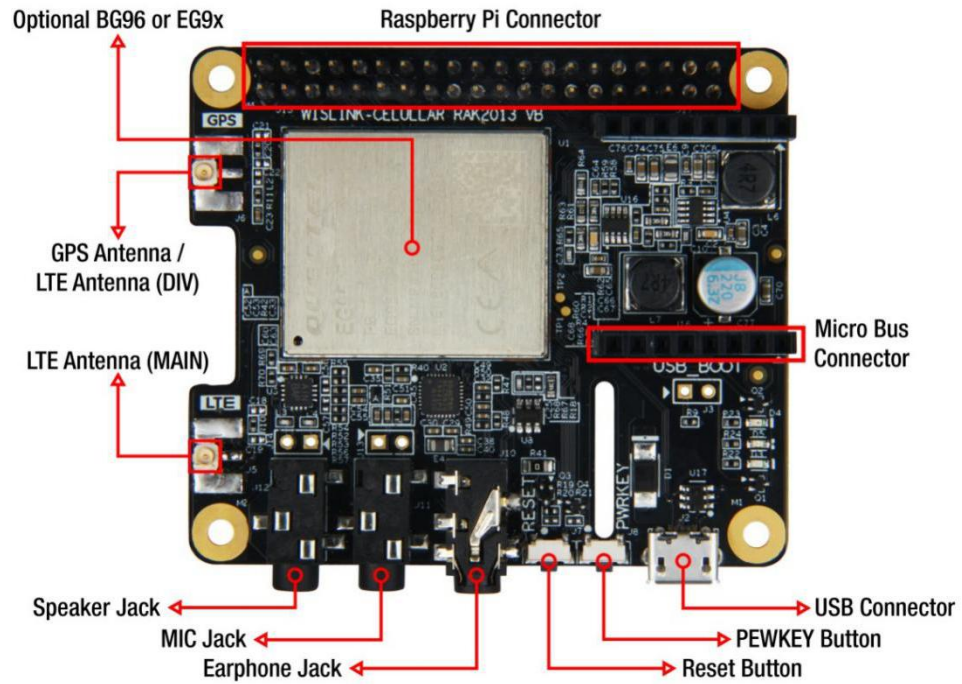

Figure 2 | RAK2013 Overview

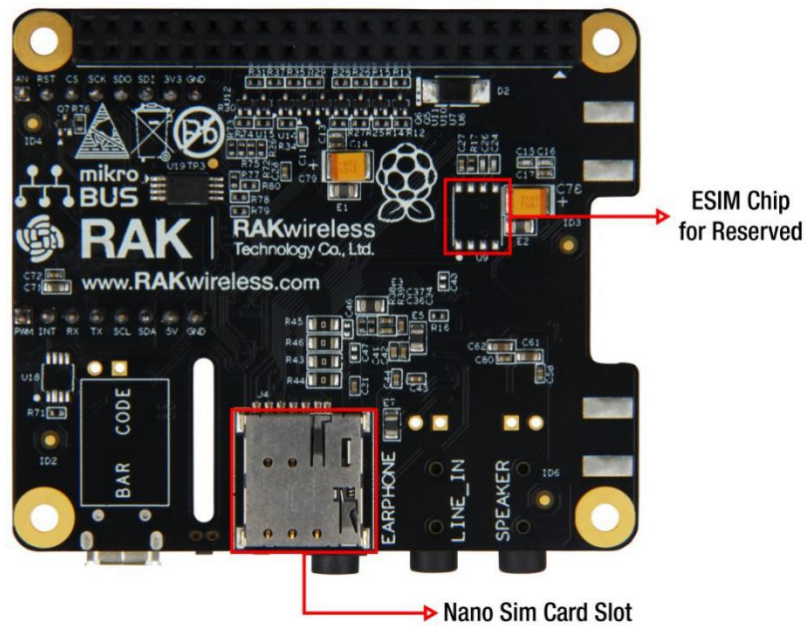

Figure 3 | RAK2013 Overview

The outer dimension of the RAK2245 is 65.0 x 56.0mm. The dimension and underside of the board is shown below.

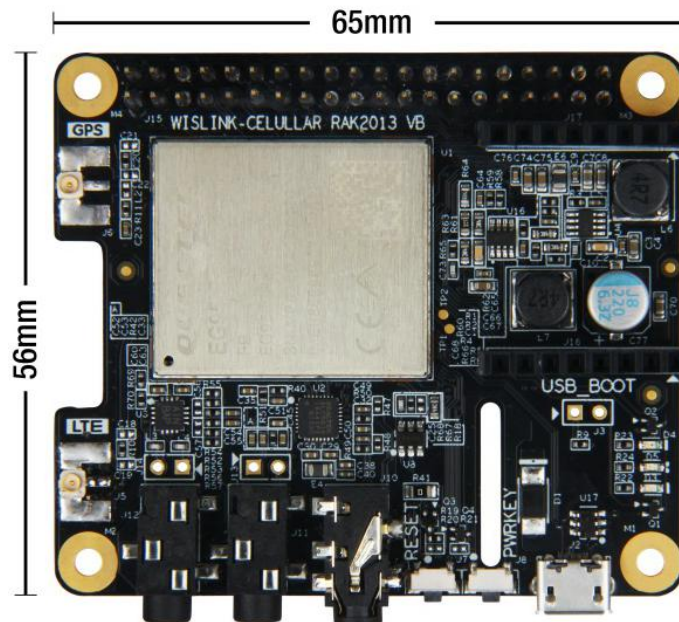

Figure 4 | RAK2013 Dimension

2.2 Functional Diagram

The diagram below shows internal architecture and external interfaces.

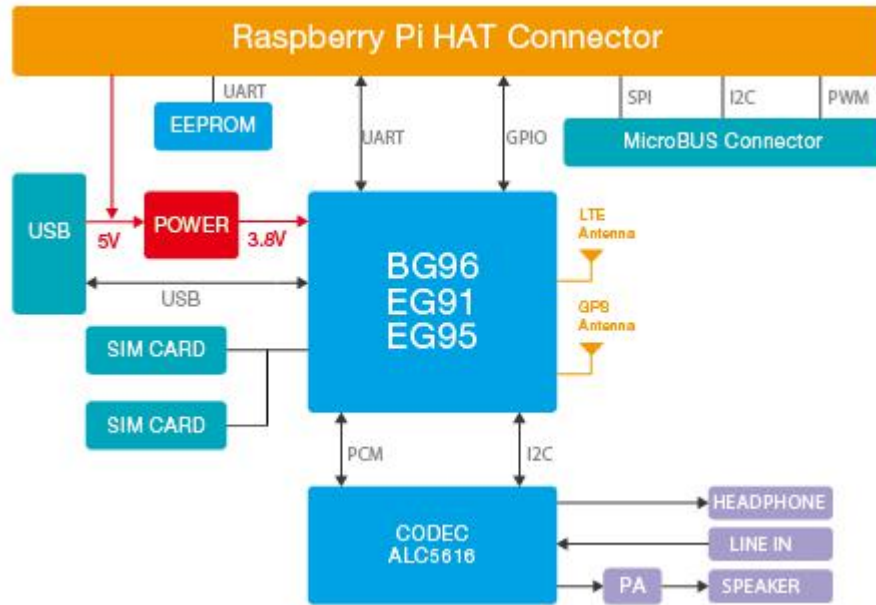

Figure 5 | RAK2013 Functional Diagram

2.3 Interfaces

It is built around Quectel BG96/EG91/EG95 module and compatible with Raspberry Pi HAT. It provides the following interfaces, headers, button and connectors.

- 40-pins Raspberry connector
- Micro USB
- MikroBus connector
- Earphone Jack
- MIC Jack
- Speaker Jack
- Reset Button
- PWRKEY Button
- Nano Sim Card slot
- LEDs
- Reset Button
- USB boot jumper

IPEX Antenna connectors:

- LTE antenna
- GPS/LTE DIV antenna

2.4 Frequency Bands and Data Rate

RAK2013 supports different frequency bands based on module mounted on the board.

2.4.1 BG96 Module

BG96 is a series of LTE Cat M1/Cat NB1/EGPRS module offering a maximum data rate of 300Kbps downlink and 375Kbps uplink.

Frequency		BG96
LTE	FDD-LTE	B1 / B2 / B3 / B4 / B5 / B8 / B12 / B18 / B19 / B20 / B26 / B28
	TDD-LTE	B39 (for CAT M1 only)
EGPRS		850 / 900 / 1800 / 1900 MHz

Table 1 | BG96 Frequency Bands

2.4.2 EG91 Module

Quectel EG91 is a series of LTE CAT 1 module optimized specially for M2M and IoT applications. It delivers M2M-optimized speeds of 10Mbps downlink and 5Mbps uplink. These make EG91 an ideal solution for numerous IoT applications that are not reliant on high speed connectivity but still require the longevity and reliability of LTE networks.

Frequency	EG91-E	EG91-NA
LTE FDD	B1 / B3 / B7 / B8 / B20 / B28A	B2 / B4 / B5 / B12 / B13
WCDMA	B1 / B8	B2 / B4 / B5
GSM / EDGE	900 / 1800 MHz	
Region	Europe	North America

Table 2 | EG91 Frequency Bands

2.4.3 EG95 Module

Quectel EG95 is a series of LTE category 4 module optimized specially for M2M and IoT applications. Adopting 3GPP Rel. 11 LTE technology, it delivers 150Mbps downlink and 50Mbps uplink data rates.

Frequency	EG95-E	EG95-NA
LTE FDD	B1 / B3 / B7 / B8 / B20 / B28A	B2 / B4 / B5 / B12 / B13
WCDMA	B1 / B8	B2 / B4 / B5
GSM / EDGE	900 / 1800 MHz	
Region	Europe	North America

Table 3 | EG95 Frequency Bands

2.5 Board Pin Out

Here are the four connectors for RAK2013 board: J3, J15, J16 and J17.

2.5.1 J3 – Boot Jumper

Jumper for BG96/EG91/EG95 USB boot.

J3 open: boot normally.

J3 shorted: Force the module to boot from USB port.

2.5.2 J15 – Raspberry Connector

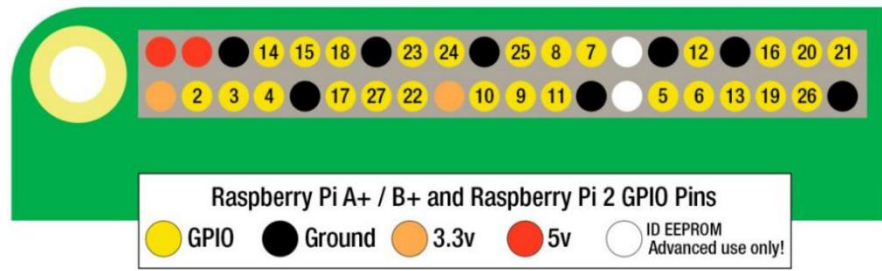

Figure 6 | RAK2013 Raspberry Connector

The table below shows the pins definition of the raspberry connector.

Pin #	RAK2013	Raspberry Definition
1	NC	3V3
2	CONN_5V0	5V
3	SDA_to_MikroBus	GPIO2 (SDA1)
4	CONN_5V0	5V
5	SCL_to_MikroBus	GPIO3 (SCL1)
6	GND	GND
7	PA_SHNT	GPIO4 (GCLK)
8	BG96_RX	GPIO14 (TXD0)
9	GND	GND
10	BG96_TX	GPIO15 (RXD0)
11	NC	GPIO17 (GPIO_GEN0)
12	BG96_PWRKEY	GPIO18 (GPIO_GEN1)
13	RST_MikroBus	GPIO27 (GPIO_GEN2)
14	GND	GND
15	BG96_DTR	GPIO22 (GPIO_GEN3)

Continued on next page...

Continuation:

Pin #	RAK2013	Raspberry Definition
16	Reserved for GPS TX	GPIO23 (GPIO_GEN4)
17	NC	3V3
18	Reserved for GPS RX	GPIO24 (GPIO_GEN5)
19	MikroBus_MOSI	GPIO10 (SPI_MOSI)
20	GND	GND
21	MikroBus_MISO	GPIO9 (SPI_MISO)
22	MikroBus_INT	GPIO25 (GPIO_GEN6)
23	MikroBus_CLK	GPIO11 (SPI_SCLK)
24	NC	GPIO8 (SPI_CE0_N)
25	GND	GND
26	MikroBus_CS	GPIO7 (SPI_CE1_N)
27	ID_SDA	ID_SD
28	ID_SCL	ID_SC
29	BG96_W_DISABLE	GPIO5
30	GND	GND
31	BG96_RESET	GPIO6
32	MikroBus_PWM	GPIO12
33	NC	GPIO13
34	GND	GND
35	NC	GPIO19
36	BG96_PSM,	GPIO16
37	BG96_AP_READY	GPIO26
38	BG96_RI	GPIO20
39	GND	GND
40	BG96_STATUS	GPIO21

Table 4 | Pin Definitions

2.5.3 J16 and J17 – MikroBus Interface

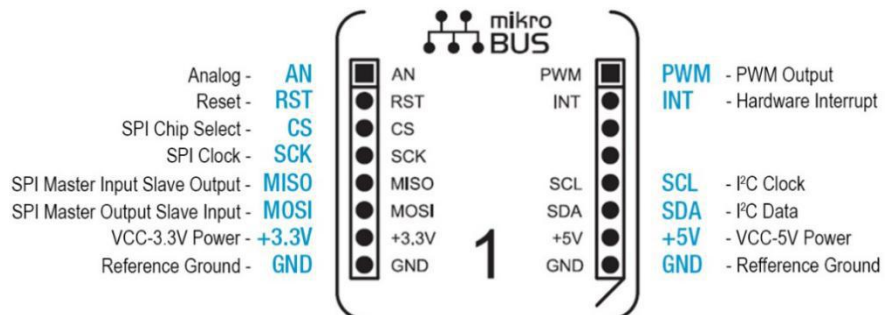

Figure 7 | MikroBus Interface

2.6 Micro-B USB Interface

A Standard Micro-B USB compliant with USB 2.0 standard specification is used to provide an interface to connect to Raspberry Pi or a PC for control of the board and firmware upgrade. The Micro-B USB pin definition is shown below:

Pin	Description
1	USB_VBUS (+5V)
2	USB_DM
3	USB_DP
4	NC
5	GND

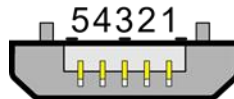

Table 5 | Micro-B USB Pins

This USB port is connected to the BG96/EG91/EG95's USB interface, The USB interface is used for AT command communication, data transmission, software debugging and firmware upgrade.

2.7 LEDs

Three LEDs are used to indicate operating status, here are their functions:

LED Color	Function	LED Status	Description
Green	Power LED	ON	Indicates that the power is good.
Blue	Status	ON	The BG96 module is powered on.
		OFF	The BG96 module is powered off.
Red	NETLIGHT	Flicker slowly (200ms High/1800ms Low)	Network searching
		Flicker slowly (1800ms High/200ms Low)	Idle
		Flicker quickly (125ms High/125ms Low)	Data transfer is ongoing
		Always high	Voice calling

Table 6 | LEDs and their functions

2.8 RESET Push Button

Reset Push Button is used to reset the BG96/EG91/EG95 module. To reset the module push the Reset Button for 1 second.

2.9 PWRKEY Push Button

When BG96 / EG91 / EG95 are in power off mode, it can be turned on to normal mode by driving the PWRKEY pin to a low level for at least 100ms. When you plug in the power socket, the module is still in power off mode, so please press the PWRKEY to power up the module. When the module is in normal mode, it can be turn to power off mode by pressing the PWRKEY button.

2.10 Antenna RF interface

The modules have two RF interfaces for LTE antenna and GPS/LTE DIV antenna over standard UFL connectors (Hirose U. FL-R-SMT) with a characteristic impedance of 50Ω. The RF ports supports both Tx and Rx, providing the antenna interface.

2.11 Power Requirements

The RAK2013 board operates at 5 volts. It can be powered by micro USB with 5V or powered by the Raspberry Pi board though 40-pin connector. Be cautious because the current of RAK2013 is about 300mA for average when working in CAT- M1 mode, it can be reach to 2A for peak when working in GSM900 mode. So you must carefully evaluate your power adapter's rating.

Parameter	Min.	Typical	Max.
Current in CAT M mode	-	300 mA	-
Current in GSM mode (peak)	-	-	2000 mA
Power off mode	-	10 mA	-

Table 7 | Power Requirements

2.12 Environmental Requirements

The table below lists the operation and storage temperature requirements:

Parameter	Min.	Typical	Max.
Operation Temp. Range	-35 °C	+25 °C	+75 °C
Extended Temp. Range	-40 °C		+80 °C
Storage Temp. Range	-40 °C		+80 °C

Table 8 | Environment Requirements

2.13 Mechanical Dimensions

Here is the detailed dimension of RAK2013 module. For full specification including electrical requirements, please visit github.com/raspberrypi/hats

Minimum HAT requirements:

- The board must be 65 x 56mm or 65 x 56.5mm.
- The board must have 3mm radius corners.
- It must have 4 mounting holes in corners and should follow mounting hole specifications.
- The board must have full 40W GPIO connector.

Mounting Holes specifications:

- Mounting holes should ideally non-plated. If plated, hole and grounding must be electrically isolated. (Do not connect these to GND)
- Mounting hole ground should be 6.2mm minimum and either isolated copper or bare board (open solder mask).
- Mounting holes should be drilled to $2.75 \pm 0.5\text{mm}$.

Further notes: It is recommended to provide slots or cutouts for camera and display flexes so camera and display can still be used with the HAT attached.

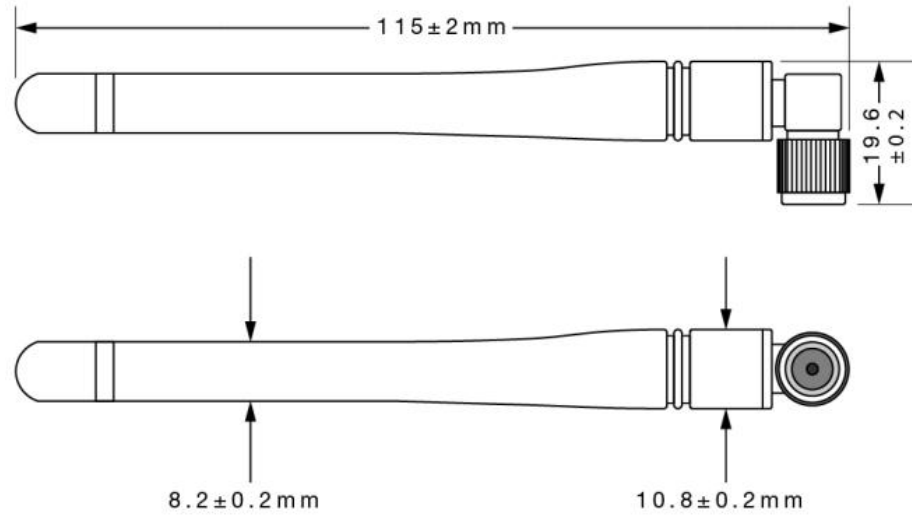

Figure 10 | LTE Antenna Dimension

3.3 Antenna Parameter

Items	Specifications						
Frequency(MHz)	700	800	880	960	1710	1880	2170
Voltage Standard Wave Radio (VSWR)	9.3	4.6	3.6	4.9	9.3	4.4	15
Gain(dBi)	1.63	1.84	1.96	2.23	0.03	0.01	1.97
Working Temperature & Humidity	T:-35 °C ~ +80 °C, H: 0% ~ 95%						
Storage Temperature & Humidity	T:-40 °C ~ +85 °C, H: 0% ~ 95%						

Table 9 | LTE Antenna Parameter

4 GPS Antenna

4.1 Overview

The GPS antenna for RAK2013 is shown below. Only the RAK2013 with BG96 supports the GPS function.



Figure 11 | GPS Antenna

4.2 GPS Antenna Dimensions

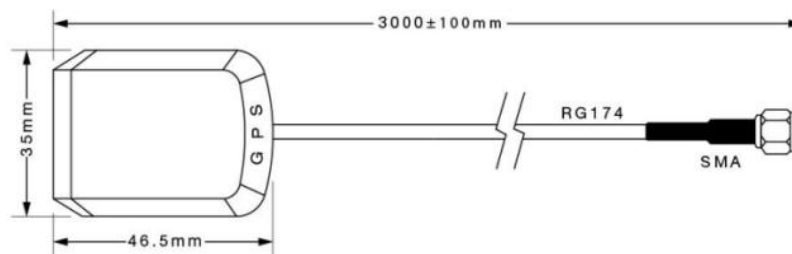

Figure 12 | GPS Antenna Dimensions

4.3 GPS Environmental Requirements

The antenna environmental requirements are listed in the table below:

Conditions	Temperature	Humidity
Working	-35 °C ~ +80 °C	0% ~ 95%
Storage	-40 °C ~ +85 °C	0% ~ 95%

Table 10 | GPS Environmental Requirements



4.4 GPS Antenna Parameter

Antenna specifications are listed in the table below:

Item	Specifications	PET
Range of Receiving Frequency	1575.42±1.1	±2.5
Center Frequency (MHz) w/ 30mm2 GND plane	1575.42	±3.0
Bandwidth (MHz) (Return Loss ≤ -10dB)	≥10	±0.5
VSWR (in Center Frequency)	≤2.0	±0.5
Gain (Zenith) (dBi Typ) w/ 70mm2 GND Plane	4.5	±0.5
Axial Ratio (dB) w/ 70mm2 GND Plane	3.0	±0.2
Polarization	Right-Handed Circular	-
Impedance (Ω)	50	-
Frequency Temperature Coefficient (ppm/°C)	0±10	-

Table 11 | GPS Antenna Parameter

Amplifier Specifications are listed in the table below:

Item	Specifications
Frequency Range	1575.42 MHz
Gain	27 dB
VSWR	≤ 2.0 V
Noise Coefficient	≤ 2.0 dBm
DC Voltage	3 ~ 5 V
DC Current	5 ± 2 mA

Table 12 | Amplifier Specifications

Environmental test performance specifications are listed below:

Item	Normal Temp.	High Temp. ¹	Low Temp. ²
Amplifier Gain	27dB ± 2.0	27dB ± 2.0	27dB ± 2.0
VSWR	≤ 2.0	≤ 2.0	≤ 2.0
Noise Coefficient	≤ 2.0	≤ 2.0	≤ 2.0

1. High temperature test: soap in temperature (85° C) and humidity (95%) chamber for 24-hour and return to normal temperature (at least for 1-hour) without visual shape change.

2. Low temperature test: soap in temperature (-40° C) chamber for 24-hour and return to normal temperature (at least for 1-hour) without visual shape change.

Table 13 | Environmental Test Performance

5 Schematics

The schematic diagram shows the power and MikroBus interface of RAK2013:

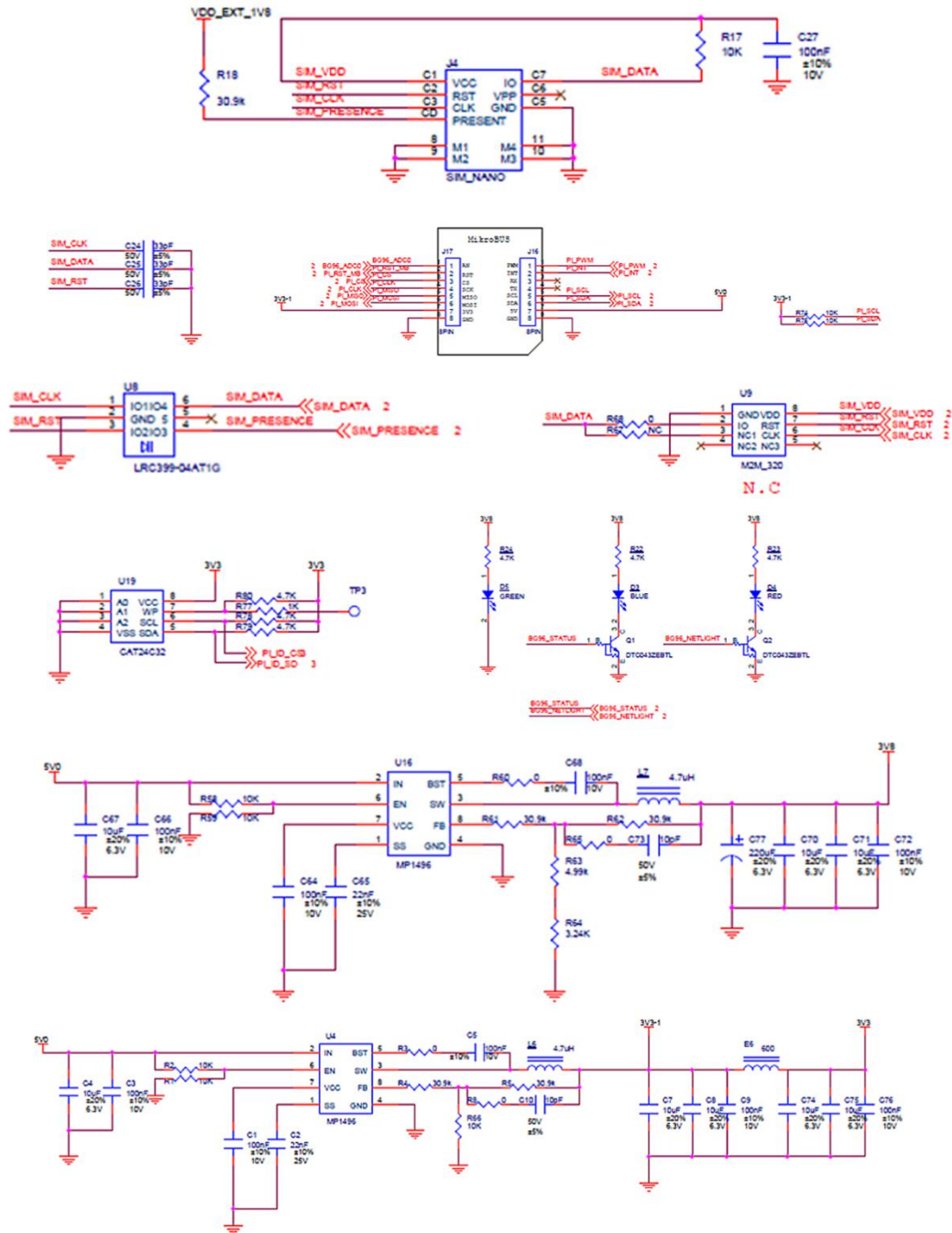

Figure 13 | Power and MikroBus Interface

This is the audio codec and amplifier schematics of RAK2013:

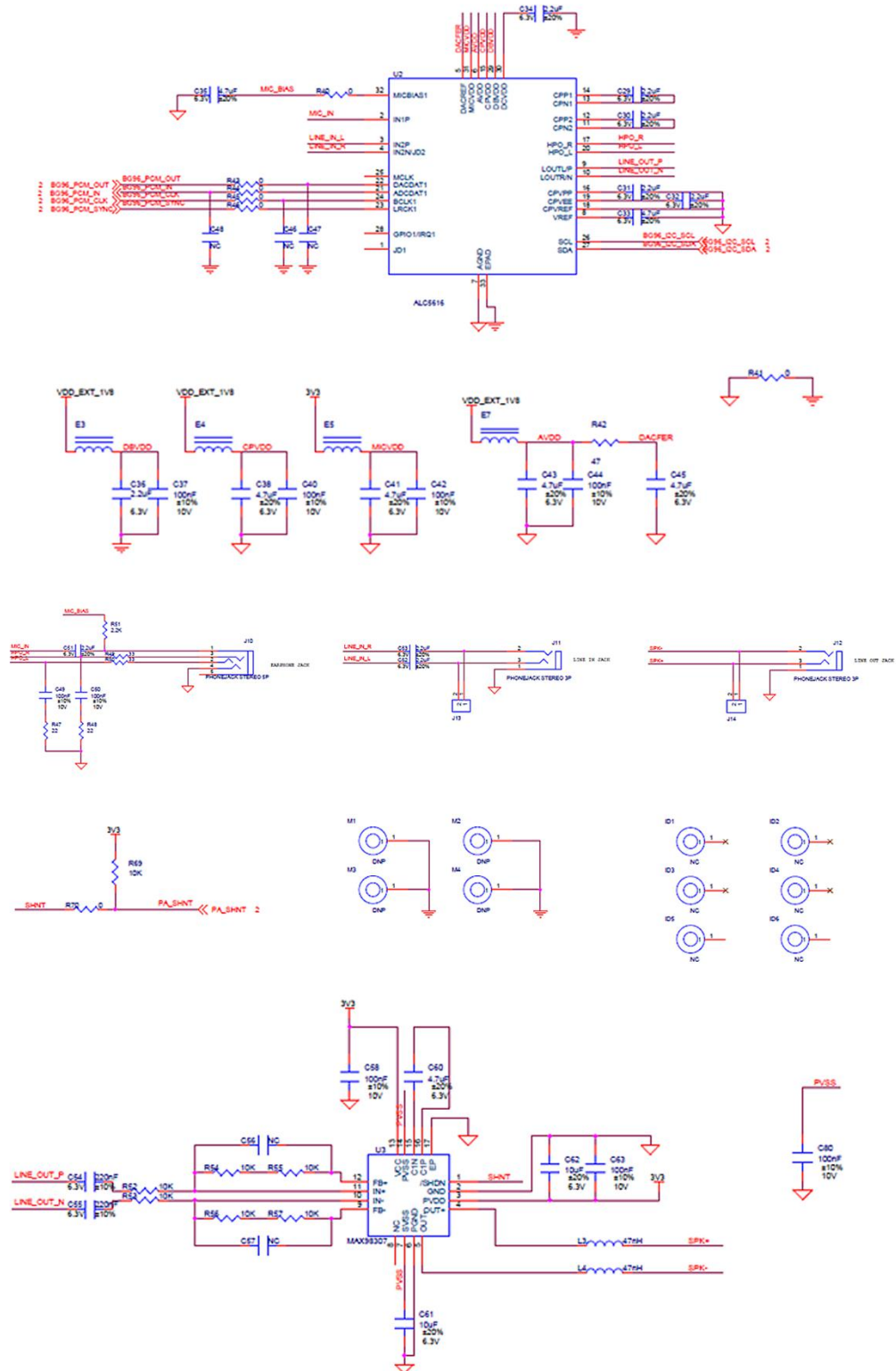







Figure 15 | Audio codec and Amplifier

6 Contact Information

Shenzhen Business

-  ken.yu@rakwireless.com
-  Room 506, Bldg B, New Compark, Pingshan First Road, Taoyuan Street, Nanshan District, Shenzhen

Shenzhen Technical

-  steven.tang@rakwireless.com
-  0755-86108311
-  Room 506, Bldg B, New Compark, Pingshan First Road, Taoyuan Street, Nanshan District, Shenzhen

7 Revision History

Revision	Description	Date
1.0	Initial version	2018-12-21
1.1	Modify the LED description	2019-09-09

8 Document Summary

Prepared by	Checked by:	Approved by:
Jeff & Penn	Terry	



About RAKwireless:

RAKwireless is the pioneer in providing innovative and diverse cellular and LoRa connectivity solutions for IoT edge devices. It's easy and module design can be used in different IoT applications and accelerate time-to-market turnover. For more information, please visit RAKwireless website at www.rakwireless.com.